



**APTA BTS-BC-RP-010-20**

Published: February 4, 2020

Bus Brake & Chassis Working Group

# Troubleshooting Transit Bus Air Systems

**Abstract:** This recommended practice provides guidelines for troubleshooting transit bus air systems, including basic design criteria, preventive maintenance and common problems.

**Keywords:** accessory system, air system, emergency brake, parking brake, service brake system, supply system, valves

**Summary:** This document establishes a recommended practice for troubleshooting transit bus air systems. Individual operating agencies should modify these guidelines to accommodate their specific equipment and mode of operation. The following recommended practices and guidelines assume that the end users have sufficient skills and knowledge to repair and maintain the related systems at a journeyman level. These skills and knowledge must also include a fluent understanding of safe shop working practices, not only for the agency but also OSHA/CCOHS/provincial/federal/state and local safety standards. A familiarity with applicable industries, component/system suppliers and vehicle manufacturers is also assumed.

**Scope and purpose:** Not all air systems are included in this document, and the tables and examples it contains are commonly used for transit applications. The purpose of this recommended practice is to provide a uniform method for air system troubleshooting in order to restore brake performance.

This document represents a common viewpoint of those parties concerned with its provisions, namely transit operating/planning agencies, manufacturers, consultants, engineers and general interest groups. The application of any recommended practices or guidelines contained herein is voluntary. APTA standards are mandatory to the extent incorporated by an applicable statute or regulation. In some cases, federal and/or state regulations govern portions of a transit system's operations. In cases where this is a conflict or contradiction between an applicable law or regulation and this document, consult with a legal advisor to determine which document takes precedence.

© 2020 The North American Transportation Services Association (NATSA) and its parent organization APTA. No part of this publication may be reproduced in any form, in an electronic retrieval system or otherwise, without prior written permission of NATSA.

# Table of Contents

Participants.....	iii
Introduction.....	iii
<b>1. Safety provisions .....</b>	<b>1</b>
<b>2. Opening statement.....</b>	<b>1</b>
<b>3. Supply system.....</b>	<b>2</b>
3.1 Overview.....	2
3.2 Troubleshooting.....	5
<b>4. Service (control) brake system.....</b>	<b>10</b>
4.1 Overview.....	10
4.2 Troubleshooting.....	12
<b>5. Parking brake and emergency brake system.....</b>	<b>13</b>
5.1 Overview.....	13
5.2 Troubleshooting.....	14
<b>6. Accessory system.....</b>	<b>17</b>
6.1 Overview.....	17
6.2 Troubleshooting.....	17
Related APTA standards.....	20
Abbreviations and acronyms.....	20
Document history.....	20

## List of Figures and Tables

<b>FIGURE 1</b> Typical Air Brake System .....	2
<b>FIGURE 2</b> Supply System Components.....	3
<b>TABLE 1</b> Air Supply System Troubleshooting Guide .....	5
<b>FIGURE 3</b> Service (Control) Brake System Components.....	11
<b>TABLE 2</b> Service (Control) Brake System Troubleshooting Guide.....	12
<b>FIGURE 4</b> Parking and Emergency Brake System Components .....	14
<b>TABLE 3</b> Parking and Emergency Brake System Troubleshooting Guide	14
<b>TABLE 4</b> Accessory System Troubleshooting Guide .....	17



## Participants

The American Public Transportation Association greatly appreciates the contributions of the **Bus Brake & Chassis Working Group**, which provided the primary effort in the drafting of this document.

At the time this standard was completed, the working group included the following members:

**Jerry Guaracino**, *Chair*

James Baldwin

Mark Barker, *Haldex Brake Products*

Tom Baurmann, *MAN Engines & Components*

Kenneth Bisson, *Greater Cleveland RTA*

Pat Breen, *SEPTA*

John Brundage, *Jacobs*

John Campo, *Power Brake*

Bruce Dahl

Garrett Davis, *Webb Wheel Products*

Carlos Manuel Delgado, *Miami-Dade Transit*

Tim Derr, *MAN Engines & Components*

David Domine, *Link Engineering Company*

Richard Dooley, *Central Ohio Transit Authority*

Joe Doyle, *Marathon Brake Systems*

Heiner Falke, *MAN Engines & Components*

Steve Farrar, *Bendix*

Mitch Forbes, *Haldex Brake Products*

Frank Forde, *Los Angeles County Metropolitan Transportation Authority*

Jim Fox, *Charlotte Area Transit System*

Victor Guillot, *WMATA*

Samet Gursel, *Maryland Transit Administration*

Jim Heuchert, *New Flyer Service Organization*

Chip Hurst, *Webb Wheel Products*

Randy King, *MGM Brakes*

Michael Konrad, *Bremser North America*

David Kwapis, *MBTA*

David Lawrence, *Fraser Gauge*

Geoff Lawrence, *Fraser Gauge*

Ricky Mares, *Harris County METRO*

Brian Markey, *Custom Training Aids*

Dennis McNichol, *Link Engineering Company*

Peter Morse, *Commercial Vehicle Components*

Kenneth Peterson, *King County Metro*

Karl Robinson, *NFI Parts*

Christopher Sabol, *Haldex Brake Products*

James Szudy, *Bendix*

Don Tirrell, *MGM Brakes*

Oscar Tostado, *OMNITRANS*

Anthony Van de Riet, *Bi-State Development Agency*

Hans Wimmer, *Friedrichshafen AG*

John Wolf, *Meritor*

Aaron Woods, *ABC Companies*

### Project team

Lisa Jerram, *American Public Transportation Association*

*Bruce Dahl, Contractor*

## Introduction

*This introduction is not part of APTA BTS-BC-RP-010-19, "Troubleshooting Transit Bus Air Systems."*

APTA recommends the use of this document by:

- individuals or organizations that operate bus transit systems;
- individuals or organizations that contract with others for the operation of bus transit systems; and
- individuals or organizations that influence how bus transit systems are operated (including but not limited to consultants, designers and contractors).

# Troubleshooting Transit Bus Air Systems

## 1. Safety provisions

**WARNING:** Failure to comply with the safety provisions in this document can result in personal injury or death.

## 2. Opening statement

Proper maintenance will ensure the safe and dependable operation of a transit vehicle. Buses should be maintained to comply with OEM maintenance guidelines, as well as federal, state, provincial and local codes and regulations.

This document is designed to support four air subsystems consisting of the following:

- supply
- service brake
- parking and emergency brake
- accessory

This document contains an overview and troubleshooting charts that describe symptoms, possible causes and corrective actions.

### 3. Supply system

**FIGURE 1**  
 Typical Air Brake System

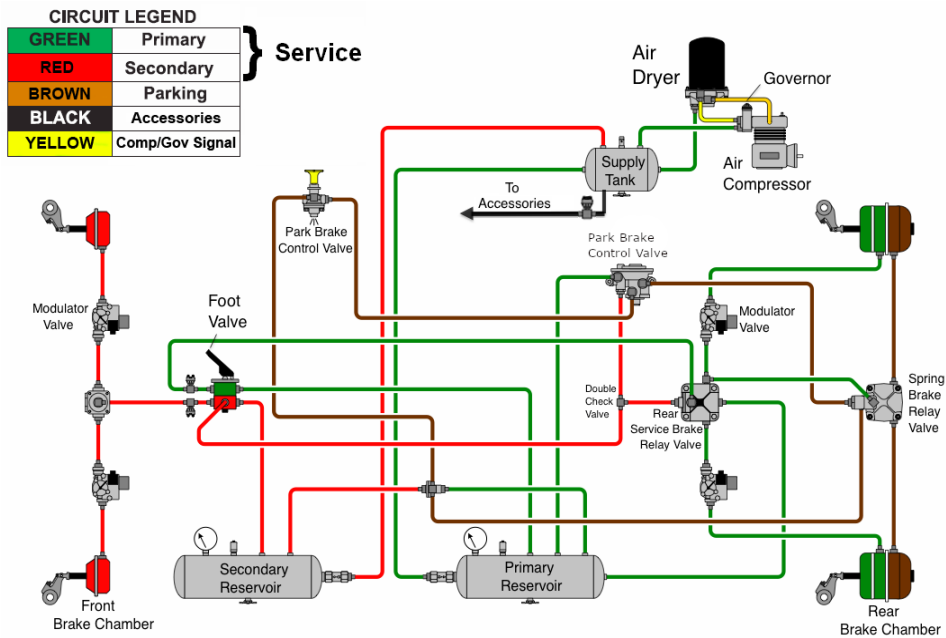

#### 3.1 Overview

**WARNING:** Alterations to vehicle air systems can lead to personal injury or death and affect the safe operation of the vehicle. No alterations shall be made that will compromise the design intent of the OEM. Replacement parts should meet OEM specifications.

The supply system (**Figure 2**) is designed to provide an adequate supply of clean, dry air to meet the needs of the following air subsystems:

- primary service brake
- secondary service brake
- parking and emergency brake
- accessories

**FIGURE 2**  
Supply System Components

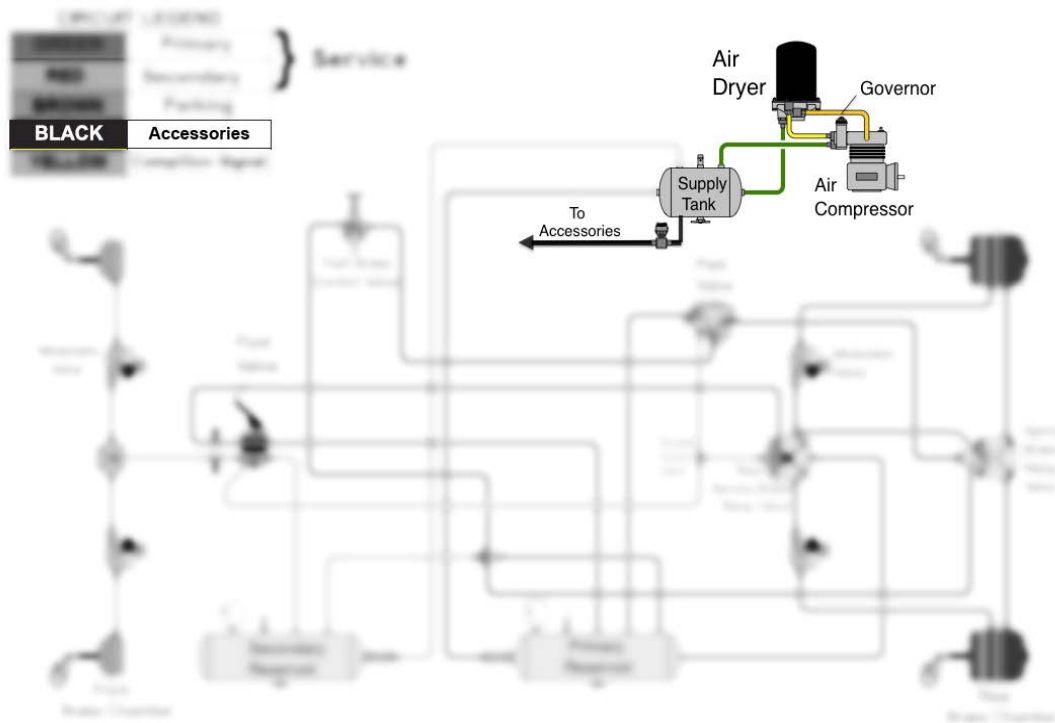

There are two common types of compressor systems: engine-driven reciprocating compressors and electric scroll compressors:

- **Engine-driven reciprocating compressors** are typically driven by the engine's front accessory drive. They typically bring air in from the engine's air inlet filter system. They may either be naturally aspirated or turbo-aspirated.
  - In naturally aspirated installations, the air is taken from ahead of the engine turbocharger system, at slightly below atmospheric pressure.
  - In turbo-aspirated installations, the air is taken from the engine's inlet manifold after the turbocharger, where it has already been raised somewhat above atmospheric pressure by the engine's turbocharger. Turbo-aspirated installations are typically preferred, as the positive inlet pressure helps reduce oil passing from the compressor's cylinders, while also increasing the efficiency of the air delivery performance. However, the air delivery temperature can be higher than naturally aspirated installations and are subject to oil and debris in the event of a turbocharger failure.
- **Electric scroll compressors** are common on hybrid, trolley or battery-electric buses. They typically have an air inlet/filtration system separate from the engine and are typically naturally aspirated. They are electrically driven at high voltage (230 or 460 V three-phase AC), either direct-drive or belt driven, and controlled by an electrical contractor system through the multiplex system. Some use oil-free scroll compressors, while others use oil-lubricated vane compressors. Vane compressors add lubricating oil to the air flow to lubricate the vanes, and therefore must use oil separators to remove the oil after compression and prior to moving to the reservoir system. Some systems also incorporate after-coolers integrated into the compressor package

**APTA BTS-BC-RP-010-20**  
**Troubleshooting Transit Bus Air Systems**

The filtered air is compressed and delivered to the supply reservoir through an air dryer. Air pressure is controlled by the governor. The air dryer removes moisture/oil and other contaminants. The supply reservoir air is protected by a one-way check valve (typically located in the air dryer). The supply system is typically protected by multiple pressure relief/safety valves. Usually a 250 psi safety valve is located on or in the air compressor, a 175 to 200 psi safety valve is located at the air dryer, and a 150 psi safety valve is installed in the supply reservoir.

If the supply reservoir pressure is controlled by a mechanical air governor, then the reservoir port on the governor receives a pressure signal from the supply reservoir. When air pressure falls below the governor cut-in setting (commonly between 100 and 120 psi), the air compression begins. When the reservoir pressure reaches the governor cut-out setting (typically 120 to 135 psi), air compression ceases and the air dryer purges.

**NOTE:** Some dryers may use other means to initiate purging.

Electrically driven air compressors may use an electronic control system. These systems would use air pressure transducers located in the reservoir system to monitor reservoir pressure and use these signals, in conjunction with the PLC system, to engage or disengage the compressor drive motor.

All reservoirs are required to include a manual drain valve. Some reservoirs may also be equipped with an automatic drain valve.

There are several important performance criteria that can be determine with troubleshooting the items in **Table 1**. They include the following:

- **Air pressure buildup time:** There are a variety of test procedures to measure buildup time. The recommended method is to build up air pressure to the governor cut-out pressure and then, by pumping the brakes, to reduce gauge pressure to less than 85 psi. With engine at fast idle (approximately 1000 RPM), the time required for air pressure to build from 85 to 125 psi should be within 45 seconds. Refer to the OEM in-service standards and/or local DOT for each vehicle.
- **Discharge line temperatures:** Discharge line temperature is measured at compressor outlet fitting and the dryer inlet fitting under maximum compressor load. The typical compressor outlet temperature should be less than 350 °F. The typical air dryer inlet temperature should be less than 160 °F.

**NOTE:** OEM specifications may vary.

- **Static air loss:** Static air loss is measured with the air system built up to governor cut-out pressure, the engine not running, service brakes released and the parking brake applied. The maximum air loss for a transit bus is 2 psi per minute.
- **Applied air loss:** Applied air loss is measured with the air system built up to governor cut-out pressure, the engine not running, the service brake fully applied and the parking brake released. The maximum applied air loss for a transit bus is 3 psi per minute.
- **Air compressor duty cycle:** Air compressor duty cycle is the percentage of time the air compressor is compressing air over a predetermined period. Duty cycles on reciprocating compressors should not exceed 30 percent, and on electrically driven scroll compressors, duty cycle should not exceed 70 percent. Duty cycles above these limits are considered excessive and may require more frequent maintenance and/or repair.

**APTA BTS-BC-RP-010-20**  
**Troubleshooting Transit Bus Air Systems**

### 3.2 Troubleshooting

**TABLE 1**  
 Air Supply System Troubleshooting Guide

<b>Symptom: Oil or air leaking at compressor connections</b>	
<b>Possible Cause(s)</b>	<b>Suggested Action(s)</b>
Leak at the air inlet fitting	If fitting is loose, re-torque or replace the fitting gasket/O-ring and then re-torque. Inspect inlet hose or hard lines and replace as necessary.
Leak at the air discharge line fitting	If fitting is loose, re-torque or replace gasket/O-ring or fitting as necessary to ensure a good seal.
Loose or broken oil line fittings	Check that fitting is secured, and check the hose for damage. Repair or replace as necessary.
Failed or overworked oil separator (lubricated vane compressor)	Check oil level of compressor. Verify proper functionality of oil separator.
<b>Symptom: Oil leaking from compressor head and/or crankcase</b> <i>(Note: A small amount of weeping from head gasket is acceptable)</i>	
<b>Possible Cause(s)</b>	<b>Suggested Action(s)</b>
Discharge line restriction	Check for restriction in discharge line and oil return line. Replace or repair as necessary. After the source of an “excessive” leak has been repaired, the gasket and head bolts or compressor should be replaced.
Leak at the bottom cover plate or sump plug	Clean and inspect sealing surfaces. Reseal cover plate with RTV sealant and re-torque. Apply thread sealant on a new sump plug, and install with the appropriate tool(s).
Leak without a clear source	Clean off the compressor and monitor periodically to isolate the source of the leak.
<b>Symptom: Fluids in the supply or service reservoir(s)</b>	
<b>Possible Cause(s)</b>	<b>Suggested Action(s)</b>
Excessive compressor duty cycle	Check for air leaks. Perform leak-down test using soapy water on air subsystems. Isolate and repair leaks.
Worn compressor	Repair/replace compressor as needed.
Air compressor discharge and/or air dryer inlet temperature too high	Check discharge fitting temperature. If compressor discharge temperature exceeds 350 °F and/or dryer inlet temperature exceeds 160 °F, then check carbon buildup in compressor exhaust fitting/line and the air dryer inlet fitting and filter. Repair or replace as needed.
Insufficient coolant flow	Inspect coolant lines and fittings for kinks, accumulated rust scale and restrictions. Consult engine and/or compressor manufacturers for specific information on testing and acceptable coolant flow rates and temperature. Replace or reroute lines as necessary.
Restricted discharge line	Check coalescent filter and replace if needed. Check discharge line for carbon buildup. If build-up thickness is greater than 1/16 in., then replace discharge line. Be sure the discharge line maintains a constant slope downward to the muffler tank and/or air dryer to prevent blockage due to freezing.
Restricted compressor air inlet	Check compressor air inlet line for restrictions (not to exceed 30 in. of water), brittleness or soft or sagging hose conditions. Repair as necessary. Check the engine air filter, and service if necessary.



**APTA BTS-BC-RP-010-20**  
**Troubleshooting Transit Bus Air Systems**

**TABLE 1**  
**Air Supply System Troubleshooting Guide**

Governor malfunction	Inspect control lines to and from the governor for air leaks and restrictions. Use soapy water to check for air leaks, and use a calibrated external gauge in the supply or service reservoir to verify that cut-in and cut-out pressures are within vehicle OEM specifications. Replace or adjust governor as necessary.
Incomplete purge cycle	Check for governor malfunction, excessive air leak, excessive duty cycle (insufficient purge time), restricted line from external purge tank, contaminated or saturated desiccant.
Restricted air dryer and/or malfunction, overdue maintenance	Verify operation of air dryer. Check for carbon buildup in dryer inlet fitting and port. Check that the dryer inlet filter is properly cleaned during the purge cycle. Follow vehicle OEM maintenance recommendations and service data information. Clean and replace if necessary.
Excessive engine oil pressure	Check the engine oil pressure with a test gauge and compare with manufacturer specifications. Consult manufacturer for specific recommendations on troubleshooting.
Air inlet pressure above 160 deg.	Check for excessive duty cycle, restricted coolant flow to compressor, dirty or plugged aftercooler or copper discharge tube.
Excessive engine crankcase pressure	Test for excessive engine crankcase pressure. A common indicator of excessive crankcase pressure is a loose or partially lifted dipstick. Repair or replace crankcase ventilation components as necessary.
Restricted oil return line to engine	Check for excessive bends, kinks or other restrictions in the external oil return line. Repair, replace or reroute as necessary.
Compressor malfunction	Replace the compressor when the above possible causes have been ruled out.
<b>Symptom: Air system is slow to build pressure</b>	
<b>Possible Cause(s)</b>	<b>Suggested Action(s)</b>
Air system leaks	Perform leak-down test on air subsystems. Listen for audible source or use soapy water to isolate the leaks (chamber, valve, hose, etc.). Repair as necessary.
Compressor unloader malfunction	Follow compressor manufacturer recommendations for determining proper operation of compressor unloader.
Damaged compressor head gasket (reciprocating compressor)	An excessive leak around the head gasket may be caused by flow restriction downstream, a dead-headed compressor, malfunctioning governor or a defective/missing safety valve. Check for restrictions or faulty safety valve, and repair as necessary. Replace compressor.
Restricted compressor discharge line	Check discharge line for carbon buildup. If buildup thickness is greater than 1/16 in., then replace discharge line. Be sure the discharge line maintains a constant slope downward to the muffler tank and/or air dryer to prevent blockage due to freezing.
Restricted compressor air inlet	Check compressor air inlet line for restrictions, (not to exceed 30 in. of water) brittleness, or soft or sagging hose conditions. Repair as necessary. Check the engine air filter and service if necessary.
Compressor malfunction	Replace the compressor when the above possible causes have been ruled out.

**APTA BTS-BC-RP-010-20**  
**Troubleshooting Transit Bus Air Systems**

**TABLE 1**  
 Air Supply System Troubleshooting Guide

<b>Symptom: Air system does not build air pressure</b>	
<b>Possible Cause(s)</b>	<b>Suggested Action(s)</b>
Governor malfunction (mechanical)	Inspect control lines to and from the governor for air leaks and restrictions. Use soapy water to check for air leaks, and use a calibrated external gauge in the supply or service reservoir to verify that cut-in and cut-out pressures are within vehicle OEM specifications. Replace or adjust governor as necessary.
Electric compressor control malfunction	Check PLC control system for proper operation. Check high-voltage supply and switching systems.
Compressor discharge line blocked	Check discharge line for carbon buildup. If buildup thickness is greater than $\frac{1}{16}$ in., then replace discharge line. Be sure the discharge line maintains a constant slope downward to the muffler tank and/or air dryer to prevent blockage due to freezing.
Frozen discharge line	Remove water from system and eliminate the discharge line dip by improving the slope. After repair, verify proper compressor function.
Air dryer heater malfunction; exhaust port frozen open	Refer to OEM recommendations for testing, and make necessary repairs.
Severe air leak in discharge line	Check for damaged discharge line, loose connections, safety or discharge valve stuck open, muffler (ping) tank malfunction.
Compressor malfunction	Replace the compressor when the above possible causes have been ruled out.
<b>Symptom: Compressor safety valve releases air</b>	
<b>Possible Cause(s)</b>	<b>Suggested Action(s)</b>
Restricted discharge line	Check coalescent filter and replace if needed. Check discharge line for carbon buildup. If buildup thickness is greater than $\frac{1}{16}$ in., then replace discharge line. Be sure the discharge line maintains a constant slope downward to the muffler tank and/or air dryer to prevent blockage due to freezing.
Downstream air system check valves or lines blocked or damaged	Inspect air lines, and verify that check valves are working properly. Repair or replace as needed.
Air dryer lines installed incorrectly	Ensure that discharge line is installed into the air dryer inlet and that delivery is routed to the supply/service reservoir.
Compressor safety valve malfunction	Replace as necessary. Verify that relief pressure is consistent with vehicle OEM specifications.

**APTA BTS-BC-RP-010-20**  
**Troubleshooting Transit Bus Air Systems**

**TABLE 1**  
 Air Supply System Troubleshooting Guide

<b>Symptom: Air dryer safety valve releases air</b>	
<b>Possible Cause(s)</b>	<b>Suggested Action(s)</b>
Severe restriction between dryer and supply/service tank	Inspect delivery lines to reservoir for restrictions, and repair as necessary.
Compressor unloader mechanism malfunction	Follow compressor manufacturer recommendations for determining proper operation of compressor unloader.
Compressor discharge spikes (turbocharged compressor)	Confirm specification with OEM.
Air dryer safety valve malfunction	Replace as necessary.
Air dryer malfunction; blockage of dryer outlet	Verify operation of air dryer. Follow vehicle OEM maintenance recommendations and service data information.
Improper governor control line installed to the reservoir	Ensure that governor control line from the reservoir is located at the top of the reservoir. Lines located at the bottom of the reservoir can become blocked or restricted by contaminants.
Governor malfunction; governor does not cut out	Inspect control lines to and from the governor for restrictions and air leaks. Use soapy water to check for leaks, and use a calibrated external gauge in the supply or service reservoir to verify that cut-in and cut-out pressures are within vehicle OEM specifications. Replace or adjust governor as necessary.
Wrong safety valve	Install correct safety valve per vehicle manufacturer's specifications.
<b>Symptom: Reservoir safety valve releases air</b>	
<b>Possible Cause(s)</b>	<b>Suggested Action(s)</b>
Compressor unloader mechanism malfunction	Follow compressor manufacturer recommendations for determining proper operation of compressor unloader.
Reservoir safety valve malfunction or wrong pressure setting for application.	The release pressure of a given valve is stamped into the side of the valve. Verify that relief pressure is at vehicle OEM or component manufacturer specifications. Connect a calibrated external pressure gauge to the service reservoir, and verify system pressure. Replace as necessary.
Governor malfunction; governor does not cut out	Inspect control lines to and from the governor for restrictions and air leaks. Use soapy water to check for leaks, and use a calibrated external gauge in the supply or service reservoir to verify that cut-in and cut-out pressures are within vehicle OEM specifications. Replace or adjust governor as necessary.
Compressor control system malfunction; compressor does not shut off	Diagnose and repair.

**APTA BTS-BC-RP-010-20**  
**Troubleshooting Transit Bus Air Systems**

**TABLE 1**  
 Air Supply System Troubleshooting Guide

<b>Symptom: Air dryer does not purge</b>	
<b>Possible Cause(s)</b>	<b>Suggested Action(s)</b>
Purge valve inoperative (mechanical control)	Repair or replace dryer purge valve. Check purge valve control circuit.
Purge valve inoperative (electric control)	Repair or replace purge solenoid valve. Check electric purge valve control circuit.
Air dryer malfunction	Verify operation of air dryer. <ul style="list-style-type: none"> <li>• Single tower type: purge valve</li> <li>• Alternating tower type: shuttle valves, purge timer</li> </ul> Follow vehicle OEM maintenance recommendations and service data information.
Plugged or restricted dryer exhaust port	Remove plug or clear restriction
Governor plumbing	Inspect control lines to and from the governor for restrictions or a plug installed in delivery port to compressor unloader. (Verify proper air line installation.) Use a calibrated external gauge in the supply or service reservoir to verify that cut-in and cut-out pressures are within vehicle OEM specifications. Replace or adjust governor as necessary.
100 percent duty cycle due to air system leakage or excessive air usage	Perform leak-down test on air subsystems. Listen for audible source, or use soapy water to isolate the leaks (chamber, valve, hose, etc.). Repair as necessary.
Improper governor control line installed to the reservoir	Ensure that the governor control line from the reservoir is located at the top of the reservoir. Lines located at the bottom of the reservoir can become blocked or restricted by contaminants. Check that reservoir and unloader lines are not reversed.
<b>Symptom: Compressor constantly cycles</b>	
<b>Possible Cause(s)</b>	<b>Suggested Action(s)</b>
Air charging system maintenance not performed	Available reservoir capacity may be reduced by buildup of contaminants in tank reservoirs. Drain and perform routine maintenance per vehicle OEM or component manufacturer service data.
Governor exhaust port plugged	Check and remove any restrictions in exhaust port.
Compressor unloader mechanism malfunction	Follow compressor manufacturer recommendations for determining proper operation of compressor unloader.
Air dryer purge valve or delivery check valve malfunction	Verify operation of air dryer. Follow vehicle OEM maintenance recommendations and service data information.
Air system leaks	Perform leak-down test on air subsystems. Listen for audible source, or use soapy water to isolate the leaks (chamber, valve, hose, etc.). Repair as necessary.
Governor malfunction	Inspect control lines to and from the governor for air leaks and restrictions. Use soapy water to check for air leaks, and use a calibrated external gauge in the supply or service reservoir to verify that cut-in and cut-out pressures are within vehicle OEM specifications. Replace or adjust governor as necessary.

**APTA BTS-BC-RP-010-20**  
**Troubleshooting Transit Bus Air Systems**

**TABLE 1**  
 Air Supply System Troubleshooting Guide

Symptom: Compressor leaks air	
Possible Cause(s)	Suggested Action(s)
Compressor leaks at air connections or ports	Check for leaking, damaged or defective compressor fittings, gaskets, etc. Repair or replace as necessary.
Compressor safety valve malfunction	Repair or replace as necessary. Verify that relief pressure is consistent with vehicle OEM specifications.
Damaged compressor head gasket	An air leak at the head gasket may indicate a flow restriction downstream of the compressor or a defective/missing safety valve. Check for restrictions or a faulty safety valve. Replace or repair compressor.
Improperly installed plugs or coolant line fittings	Inspect for loose or over-torqued fittings. Reseal and tighten loose fittings and plugs as necessary. If over-torqued fittings and plugs have cracked ports in the head, then the compressor will need to be replaced.
Symptom: Compressor leaks coolant (external)	
Possible Cause(s)	Suggested Action(s)
Damaged compressor head gasket	A leaking head gasket may indicate a flow restriction downstream of the compressor or a defective/missing safety valve. Check for restrictions or a faulty safety valve. Check for correct coolant flow. Check for air blockage in discharge line and air dryer. Once the source of the problem has been repaired, replace head or compressor.
Leak at fittings or lines	Inspect for loose or over-torqued fittings. Reseal and tighten loose fittings and plugs as necessary. If over-torqued fittings and plugs have cracked ports in the head, then the compressor will need to be replaced
Symptom: Compressor pressurizes engine coolant system	
Possible Cause(s)	Suggested Action(s)
Porous compressor head casting	If casting porosity is detected, then replace head or compressor.
Sealing land surface finish compromised	Replace head or compressor.
Damaged compressor head gasket	Check for downstream air blockage in the discharge line and air dryer. Make necessary repairs, and replace head or compressor.

## 4. Service (control) brake system

### 4.1 Overview

All vehicles on the road require a service (or control) braking system; see **Figure 3**. Simply stated, when the driver steps on the brake pedal, the vehicle will slow or stop in direct proportion to the amount of treadle pedal force exerted. Equally important to the vehicle control afforded by a brake application is the driver's ability to release the brakes when necessary. Therefore, the entirety of the brake's service system involves controlled brake pedal application and release. Since the majority of normal vehicle braking involves gradual slowing, as opposed to panic stopping, the driver must be able to make controlled hard or soft stops as required. This correlation between treadle pedal force and stopping power is called "modulation."

**APTA BTS-BC-RP-010-20**  
**Troubleshooting Transit Bus Air Systems**

**FIGURE 3**  
 Service (Control) Brake System Components

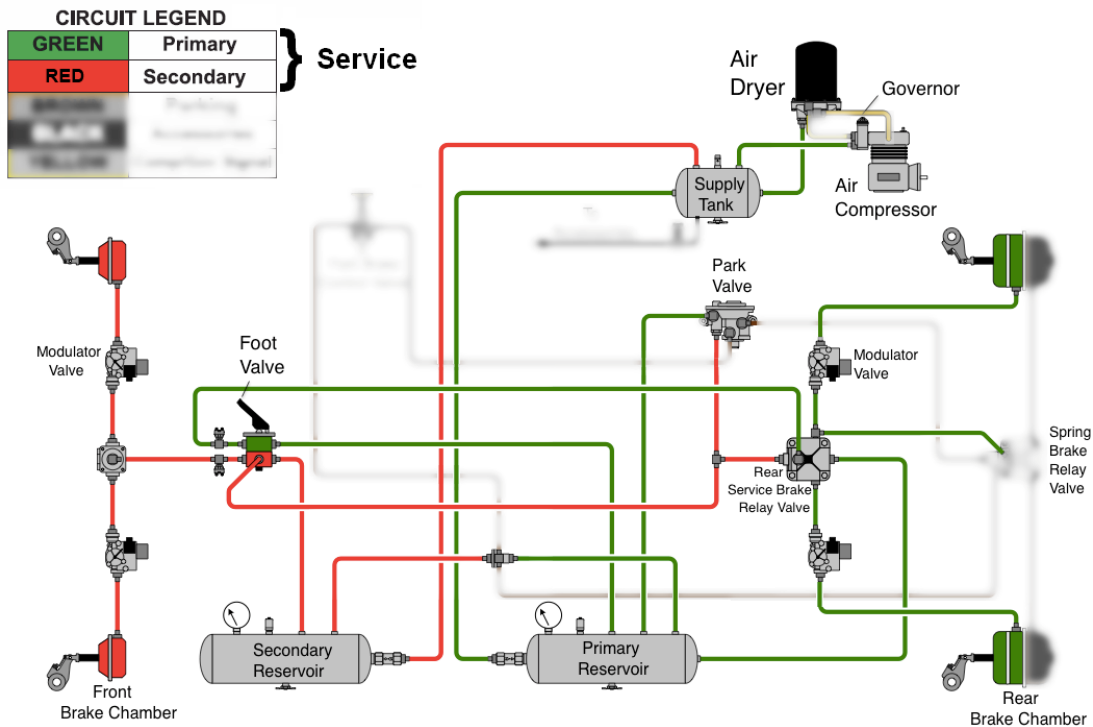

In an air brake system, service brakes are pneumatically powered. The brake pedal, when pressed, mechanically operates the brake (treadle) valve, which in turn delivers air pressure to brake chambers (actuators) that convert air pressure into linear mechanical force. When the pedal is released, air pressure from the chambers is released to the atmosphere, thereby releasing the mechanical force from the foundation brake components.

In addition to the brake (treadle) valve and chambers, stop light switches, relay valves and quick-release valves are employed in the service brake system. During a service brake application, air pressure is delivered to the stop light switch, which completes an electrical circuit to apply the brake lights. A quick-release valve is typically used to distribute delivery air pressure to each front brake chamber and quickly release air, without it having to travel back to the treadle valve. The relay valve located near the rear axle speeds up the application and release of the rear brakes. It has a dedicated supply of air from the primary reservoir, requiring only an air control signal from the treadle valve. Quick-release valves can also be used in the control circuit to speed application and release of relay valve control signals.

In the interest of safety through redundancy, service brakes have independent rear (primary) and front (secondary) air circuits. In the event of an air loss in one of these circuits, the remaining circuit will still function to permit vehicle braking via the treadle valve.

**APTA BTS-BC-RP-010-20**  
**Troubleshooting Transit Bus Air Systems**

## 4.2 Troubleshooting

**TABLE 2**  
 Service (Control) Brake System Troubleshooting Guide

<b>Symptom: Poor brake modulation; cannot make gradual brake application</b>	
<b>Possible Cause(s)</b>	<b>Suggested Action(s)</b>
Brake (treadle) valve problem, external sticking	Inspect linkage, treadle pin, roller, boot and piston. Look for corrosion and/or contamination. Replace or repair as necessary. (Reference APTA recommended practice "Transit Bus Brake Valve Treadle Assembly Maintenance".)
Internal damage; primary and/or secondary piston sticking	Repair or replace brake (treadle) valve.
Delivery air line restriction	If brake (treadle) valve is functioning properly, then check downstream delivery lines for uniform pressure modulation. Replace damaged or restricted lines.
Service relay valve primary piston sticking	If modulated air pressure is delivered to relay valve service (control) port but modulated air pressure is not being delivered, then repair or replace service relay valve.
<b>Symptom: Leaking exhaust port at brake, relay, quick-release valve</b>	
<b>Possible Cause(s)</b>	<b>Suggested Action(s)</b>
Air leak downstream (valve may be functioning correctly)	Remove delivery lines, and check for air flowing back from downstream source. If so, identify source of air pressure. Possible internal leak in spring brake or anti-compound check valve in spring brake relay valve. Repair or replace component as necessary.
Malfunctioning exhaust valve	Repair or replace brake (treadle) valve or relay valve as necessary.
<b>Symptom: Excessive air pressure loss on brake application</b>	
<b>Possible Cause(s)</b>	<b>Suggested Action(s)</b>
Air leak(s) in delivery circuit	Perform leak-down test on air subsystems. Listen for audible source or use soapy water to isolate the leaks (chamber, valve, hose, etc.). Repair as necessary.
<b>Symptom: Vehicle pulling upon brake application</b>	
<b>Possible Cause(s)</b>	<b>Suggested Action(s)</b>
Air restriction on delivery circuit downstream from relay or quick-release valve on one side only	If the foundation brakes have been ruled out as the source of the problem, then look for air restriction on delivery line to brake chamber on side opposite direction of pull (most likely on steer axle).
<b>Symptom: Brakes not releasing or releasing slowly after service application</b>	
<b>Possible Cause(s)</b>	<b>Suggested Action(s)</b>
Bad relay valve or quick-release valve	Make brake application and release. Remove service control line. If relay or QR valve does not release, then replace valve.
Internal service brake air line collapse, acting like "check valve"	Make brake application. Remove service control line. If relay or QR valve <i>does</i> release, then check service line to see if there is a backward restriction. Replace line as needed.
Bad brake (treadle) valve exhaust valve	Make brake application and release. Remove service control line. If relay or QR valve <i>does</i> release, then check service line to see if there is a restriction. If there is no restriction, then replace brake (treadle) valve.

## 5. Parking brake and emergency brake system

### 5.1 Overview

**WARNING:** Parking brakes are not the emergency brakes.

All buses must be equipped with an emergency brake system and parking brakes (**Figure 4**). The parking brake's function is to hold the bus stationary on a specified grade at GVWR. The parking brakes are held on by mechanical force to ensure that they remain activated while the bus is stationary, even if air pressure leaks away. The emergency system's function is to provide braking force at the primary brakes, to assist the intact secondary brake system in the event of a primary brake system failure.

The parking brake system uses a spring brake chamber that contains a powerful spring that mechanically applies the foundation brakes. To allow normal vehicle operation, the spring force is held back by air pressure (referred to as "hold-off air"), which releases the foundation brake. A parking brake control valve in the operator's compartment allows the operator to either apply this air to release the springs and drive the vehicle or to exhaust this air to apply the springs to hold the vehicle stationary. Park control valves are typically pressure-sensitive, normally closed, on/off valves that automatically move to the exhaust position (applying the parking brake) when supply pressure falls below the required minimum for the particular valve installed. A leak in the parking brake system, which causes both primary and secondary service air to be lost, will exhaust hold-off air and cause the springs to apply, and slow a moving vehicle to a parked position or keep a parked vehicle stationary.

The emergency brake system uses the spring brake chambers and parking brake air distribution components to provide modulated braking on the rear axle(s) in the event of rear (primary) air reservoir pressure loss. When primary pressure is lost, the application of the intact front (secondary) brake system causes the hold-off air to be partially released (in proportion to the amount of front brake application, via treadle application). The result is controlled partial application (and release) of the primary brakes via the spring brake chambers. This provides increased stopping performance when a rear (primary) system failure occurs.

Parking brake and emergency brake systems are typically composed of six components:

- air reservoirs
- spring brake control valve
- double check valve
- dash control valve (park push-pull valve)
- spring brake chambers
- foundation brake components

**NOTE:** The combined forces of the park springs and the service air pressure may damage the foundation brake components. Most vehicles are equipped with a feature called anti-compounding that prevents the application of both the spring and service brake forces.



**APTA BTS-BC-RP-010-20**  
**Troubleshooting Transit Bus Air Systems**

**FIGURE 4**  
 Parking and Emergency Brake System Components

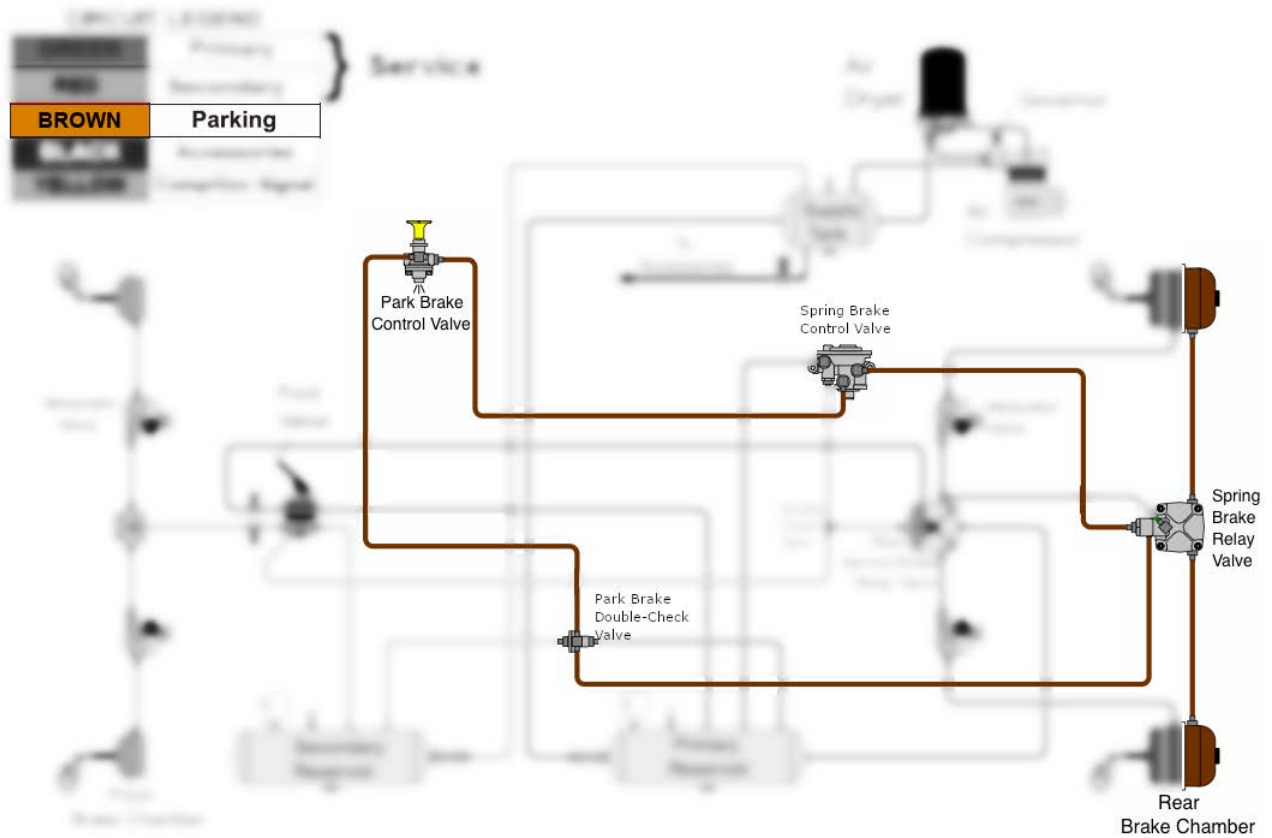

**5.2 Troubleshooting**

**TABLE 3**  
 Parking and Emergency Brake System Troubleshooting Guide

<b>Symptom: Parking brakes don't apply</b>	
<b>Possible Cause(s)</b>	<b>Suggested Action(s)</b>
Malfunctioning dash control valve	Confirm that the correct parking brake valve is installed. Check that the exhaust port isn't plugged. Check for air pressure at the inlet port. If air pressure is not adequate, then check for restrictions upstream. If pressure is present, then push the valve down and check for pressure in the outlet. If not, repair or replace the valve. If pressure is present, then check downstream.
Brake hoses damaged	Check for kinks/pinches or restrictions. Replace any damaged brake hoses.
Malfunctioning relay valve	Remove all signal lines to the valve. If the brakes apply, then look upstream of the relay valve. If the brakes fail to apply, then carefully remove a spring brake hose. If the brakes release, then replace the relay valve.

**APTA BTS-BC-RP-010-20**  
**Troubleshooting Transit Bus Air Systems**

**TABLE 3**  
 Parking and Emergency Brake System Troubleshooting Guide

Foundation brake problem	Diagnose and repair the problem. Reference APTA BTS-SS-RP-004-07, "Transit Bus Front and Rear Axle S-Cam Brake Reline," APTA BTS-BC-RP-006-17, "Transit Bus Air Disc Brake Operation and Wheels-On Inspection," and APTA BTS-BC-RP-007-17, "Transit Bus Air Disc Brake Operation and Wheels-Off Inspection."
Inversion or spring brake control valve problem	Make sure the valve is plumbed correctly. Refer to the OEM on the functionality and testing of the valve.
<b>Symptom: Parking brakes don't release</b>	
<b>Possible Cause(s)</b>	<b>Suggested Action(s)</b>
Insufficient pressure in spring brake chambers	Confirm adequate supply pressure. Check for restrictions in signal and spring brake delivery system.
Chamber air leak	Check for a failed diaphragm or seal by listening for an external leak with the spring brakes released. Check for an internal seal leak by removing the service brake hoses, and release the spring brake. Repair or replace the chamber if a leak is detected during either test. <b>WARNING:</b> Do not disassemble spring brake chamber.
Foundation brake problem	Diagnose and repair the problem. Reference APTA BTS-SS-RP-004-07, "Transit Bus Front and Rear Axle S-Cam Brake Reline," APTA BTS-BC-RP-006-17, "Transit Bus Air Disc Brake Operation and Wheels-On Inspection," and APTA BTS-BC-RP-007-17, "Transit Bus Air Disc Brake Operation and Wheels-Off Inspection."
Inversion or spring brake control valve problem	Make sure the valve is plumbed correctly. Refer to the OEM on the functionality and testing of the valve.
Debris in spring brake chamber	Ensure that the caging bolt plug is in place.
Malfunctioning dash control valve	Confirm that the correct parking brake valve is installed. Replace with correct parking brake valve.
<b>Symptom: Dash control valve doesn't latch</b>	
<b>Possible Cause(s)</b>	<b>Suggested Action(s)</b>
Low supply air pressure at control valve	Diagnose low air pressure on inlet port.
Malfunctioning dash control valve	Confirm that the correct parking brake valve is installed. Replace with correct parking brake valve.
<b>Symptom: Parking brakes don't hold</b>	
<b>Possible Cause(s)</b>	<b>Suggested Action(s)</b>
Foundation brake problem or improper adjustment	Check for proper push rod travel, broken or damaged foundation parts, glazed lining, lining thickness, etc. Repair as necessary. Reference APTA BTS-SS-RP-004-07, "Transit Bus Front and Rear Axle S-Cam Brake Reline," APTA BTS-BC-RP-006-17, "Transit Bus Air Disc Brake Operation and Wheels-On Inspection," and APTA BTS-BC-RP-007-17, "Transit Bus Air Disc Brake Operation and Wheels-Off Inspection."
Broken or weak parking brake spring(s)	If foundation brakes are satisfactory, replace the chamber.
Incorrect brake adjuster angle/ incorrect push rod length.	Maximum brake efficiency is achieved with brake adjuster at 90 deg., ±10 deg. Verify that foundation brake is set up according to the manufacturer's specifications.
Caging bolt engaged	Disengage the caging bolt.

**APTA BTS-BC-RP-010-20**  
**Troubleshooting Transit Bus Air Systems**

**TABLE 3**  
 Parking and Emergency Brake System Troubleshooting Guide

<b>Symptom: Parking brakes are slow to apply</b>	
<b>Possible Cause(s)</b>	<b>Suggested Action(s)</b>
Foundation brake problem or improper adjustment	Check for proper push rod travel, return springs, binding in camshaft or anchor pins, broken or damaged foundation parts, etc. Repair as necessary. Reference APTA BTS-SS-RP-004-07, "Transit Bus Front and Rear Axle S-Cam Brake Reline," APTA BTS-BC-RP-006-17, "Transit Bus Air Disc Brake Operation and Wheels-On Inspection," and APTA BTS-BC-RP-007-17, "Transit Bus Air Disc Brake Operation and Wheels-Off Inspection."
Restriction in the air system	Check hoses for kinks/pinches or restrictions. Replace any damaged brake hoses. Check valves for contamination and proper operation.
Brake chamber malfunction	Repair or replace the brake chamber as necessary.
<b>Symptom: Parking brakes are slow to release</b>	
<b>Possible Cause(s)</b>	<b>Suggested Action(s)</b>
Low air system pressure	Diagnose air system pressure. Refer to Section 3.1.
Foundation brake problem or improper adjustment	Check for proper push rod travel, return springs, binding in camshaft or anchor pins, broken or damaged foundation parts, etc. Repair as necessary. Reference APTA BTS-SS-RP-004-07, "Transit Bus Front and Rear Axle S-Cam Brake Reline," APTA BTS-BC-RP-006-17, "Transit Bus Air Disc Brake Operation and Wheels-On Inspection," and APTA BTS-BC-RP-007-17, "Transit Bus Air Disc Brake Operation and Wheels-Off Inspection."
Restriction in the air system	Check hoses for kinks/pinches or restrictions. Replace any damaged brake hoses. Check valves for contamination and proper operation.
Brake chamber malfunction	Repair or replace the brake chamber as necessary.
Leak in the air system	Perform leak-down test on air subsystems. Listen for audible source or use soapy water to isolate the leaks (chamber, valve, hose, etc.). Repair as necessary.
Contaminated valve	Replace or repair valve as necessary. Check air compressor/dryer system. Drain moisture from air tanks. Replace contaminated component
<b>Symptom: Self-application</b>	
<b>Possible Cause(s)</b>	<b>Suggested Action(s)</b>
Air leak in delivery circuit	Perform leak-down test on air subsystems. Listen for audible source or use soapy water to isolate the leaks (chamber, valve, hose, etc.). Repair as necessary.
Low system pressure	Diagnose air system pressure. Refer to Section 3.1.
Brake chamber malfunction	Repair or replace the brake chamber as necessary.
Malfunctioning dash control valve	Confirm that the correct parking brake valve is installed. Replace with correct parking brake valve.
Inversion or spring brake control valve problem	Make sure the valve is plumbed correctly. Refer to the OEM on the functionality and testing of the valve.

**APTA BTS-BC-RP-010-20**  
**Troubleshooting Transit Bus Air Systems**

**TABLE 3**  
 Parking and Emergency Brake System Troubleshooting Guide

Contaminated valve	Replace or repair valve as necessary. Check air compressor/dryer system. Drain moisture from air tanks. Replace contaminated component.
<b>Symptom: Dash indicator problem</b>	
<b>Possible Cause(s)</b>	<b>Suggested Action(s)</b>
Faulty switch	Replace the switch and or bulb.

## 6. Accessory system

### 6.1 Overview

Most buses are equipped with an accessory air tank. Air is supplied to the accessory tank by the supply system. The pressure protection valve allows pressure to build in the brake reservoirs to the set opening pressure before opening and allowing the accessory tank to pressurize and equalize with the other brake reservoirs. If the accessory tank fails or all air is lost from the accessory tank, then the pressure protection valve closes at the set closing pressure (typically 10 to 15 psi lower than the opening pressure), ensuring that pressure is retained in the braking system reservoirs. The tank also is equipped with a drain valve.

Prior to diagnosing any accessory, it is important to confirm adequate air supply.

The following components are typically supplied by the accessory tank:

- leveling valves
- kneeling valves
- wiper motor
- driver’s seat
- spinner filter
- entrance door motor
- exit door motor

### 6.2 Troubleshooting

**TABLE 4**  
 Accessory System Troubleshooting Guide

<b>Symptom: Accessories operating slowly or not operating</b>	
<b>Possible Cause(s)</b>	<b>Suggested Action(s)</b>
Insufficient air supply	Diagnose air system pressure. Refer to Section 3.1.
Air system leak	Perform leak-down test on air subsystems. Listen for audible source or use soapy water to isolate the leaks (chamber, valve, hose, etc.). Repair as necessary.
Pressure protection valve not opening	Check accessory tank pressure. If pressure is low, then replace valve.
Restricted lines	Check for kinked hose or blocked tubing, and leaking or cracked air lines. Repair and replace.
Moisture in air tank	Drain moisture from air tanks. Check air compressor/dryer system. Replace contaminated component(s).

**APTA BTS-BC-RP-010-20**  
**Troubleshooting Transit Bus Air Systems**

**TABLE 4**  
 Accessory System Troubleshooting Guide

<b>Symptom: Suspension not leveling</b>	
<b>Possible Cause(s)</b>	<b>Suggested Action(s)</b>
Insufficient air supply	Diagnose air system pressure. Refer to Section 3.1.
Air system leaks	Perform leak-down test on air subsystems. Listen for audible source or use soapy water to isolate the leaks (chamber, valve, hose, etc.). Repair as necessary.
Pressure protection valve not opening	Check accessory tank pressure. If pressure is low, then replace valve.
Restricted lines	Check for kinked hose or blocked tubing. Repair or replace.
Leveling valve control arms	Inspect linkage for looseness, flipping or other damage. Repair or replace as necessary.
Moisture in air tank	Drain moisture from air tanks. Check air compressor/dryer system. Replace contaminated component(s).
Air spring	Check air spring for leaks. Replace as necessary. Check for mismatched parts.
<b>Symptom: Suspension not kneeling (lowering)</b>	
<b>Possible Cause(s)</b>	<b>Suggested Action(s)</b>
Electrical malfunction	Refer to the electrical section in the OEM manual.
Kneel valve out of adjustment	Refer to the adjustment procedures in the OEM manual for the kneeling system.
<b>Symptom: Suspension not recovering (raising)</b>	
<b>Possible Cause(s)</b>	<b>Suggested Action(s)</b>
Kneel valve malfunction	Refer to the adjustment procedures in the OEM manual for the kneeling system.
Level valve control arm(s) out of adjustment	Inspect for damaged, bent, broken or flipped arm. Repair or replace as necessary.
Electrical malfunction	Refer to the electrical section in the OEM manual.
Malfunctioning quick-fill valve	Check valve operation. Repair or replace as necessary.
Air supply	Diagnose air system pressure. Refer to Section 3.1.
<b>Symptom: Pneumatic door operation, entrance door, exit door (not opening or closing)</b>	
<b>Possible Cause(s)</b>	<b>Suggested Action(s)</b>
Air supply	Diagnose air system pressure. Refer to Section 3.1.
Air system leaks	Perform leak-down test on air subsystems. Listen for audible source or use soapy water to isolate the leaks (chamber, valve, hose, etc.). Repair as necessary.
Restricted lines	Check for kinked hose or blocked tubing. Repair and replace as necessary.
Pressure protection valve not opening	Check accessory tank pressure. If pressure is low, then replace valve.
Door out-of-mechanical adjustment	Check mechanical linkage for binding and sticking. Refer to the adjustment procedures in the OEM manual for door speed adjustments.

**APTA BTS-BC-RP-010-20**  
**Troubleshooting Transit Bus Air Systems**

**TABLE 4**  
 Accessory System Troubleshooting Guide

Rotary valve (air shutoff valve)	Check operator door control valve.
Contaminated valve	Check air compressor/dryer system. Drain moisture from air tanks Replace contaminated component.
<b>Symptom: Driver's seat not operating</b>	
<b>Possible Cause(s)</b>	<b>Suggested Action(s)</b>
Supply line	Check supply air line to driver's seat. Check for kinked hose, blocked tubing, leaking or cracked air lines. Repair or replace as necessary.
Insufficient air supply	Diagnose air system pressure. Refer to Section 3.1.
Control valves (air shutoff valve)	Close or replace defective drain valves.
Pressure protection valve	Check accessory tank pressure. If pressure is low, then replace valve.
<b>Symptom: Malfunctioning wipers</b>	
<b>Possible Cause(s)</b>	<b>Suggested Action(s)</b>
Insufficient air supply	Diagnose air system pressure. Refer to Section 3.1.
Mechanical linkage	Check mechanical linkage for wear, damage, binding or sticking. Lubricate, replace or rebuild as possible.
Control valves	Check pressure at supply and delivery port at the valve. If supply pressure is low, then check for restrictions between pressure protection valve and control pressure. Repair or replace as necessary. If delivery pressure is low, then replace valve. If delivery pressure is adequate, then check wiper motor.
Wiper motor	Refer to OEM manual for proper test procedure.

**APTA BTS-BC-RP-010-20**  
**Troubleshooting Transit Bus Air Systems**

**Related APTA standards**

- APTA BTS-SS-RP-004-07**, “Transit Bus Front and Rear Axle S-Cam Brake Reline”
- APTA BTS-BC-RP-006-17**, “Transit Bus Air Disc Brake Operation and Wheels-On Inspection”
- APTA BTS-BC-RP-007-17**, “Transit Bus Air Disc Brake Operation and Wheels-Off Inspection”
- APTA BTC-BC-RP-008-19**, “Transit Bus Brake Valve Treadle Assembly Maintenance”

**Abbreviations and acronyms**

- AC**           alternating current
- CCOHS**      Canadian Centre for Occupational Health and Safety
- GVWR**       gross vehicle weight rating
- NATSA**      North American Transportation Services Association
- OEM**         original equipment manufacturer
- OSHA**       Occupational Safety and Health Administration
- PLC**         programmable logic controller
- psi**          pounds per square inch
- QR**          quick release
- RPM**         revolutions per minute
- RTV**         room temperature vulcanizing
- V**            volt

**Document history**

<b>Document Version</b>	<b>Working Group Vote</b>	<b>Public Comment/ Technical Oversight</b>	<b>CEO Approval</b>	<b>Policy &amp; Planning Approval</b>	<b>Publish Date</b>
First published	July 3, 2019	Sept. 13, 2019	Nov. 15, 2019	Jan. 31, 2020	Feb. 4, 2020