



## APTA PR-M-S-005-98, Rev. 4

First Published: June 15, 1998

First Revision: May 5, 2003

Second Revision: May 18, 2007

Third Revision: June 30, 2012

Fourth Revision: July 27, 2018

PRESS Mechanical Working Group

# Code of Tests for Passenger Car Equipment Using Single Car Testing

**Abstract:** This document establishes a standard for the testing of a single passenger car equipped with 26-C and newer style brake equipment.

**Keywords:** single car test device, single car test, 26-C, Brake Test

**Summary:** This standard provides a means by which passenger car brake equipment can be tested before being entered into service. The practices outlined herein may be modified by the equipment manufacturer/operating authority as long as the original intent of the publication has been maintained. All modifications to this publication may be subject to inspection to ensure that the equipment is tested properly.

**Scope and purpose:** Revision 4 of this Standard shall be used after March 1<sup>st</sup>, 2019, for testing 26-C or equivalent type brake equipment. The Single Car Test Device and test racks may need to be modified to meet these requirements. All equipment shall be tested at the same brake pipe pressure used in service operation. The purpose of this standard is to describe the test procedures by which a general check on the condition of passenger brake equipment on cars can be made. It covers cars while in service and cars having undergone “periodic repairs.” The Single Car Testing Device enables this testing to be accomplished without removal of any components from the car. The latest revision of this standard shall be available at the location where testing is performed.

*This document represents a common viewpoint of those parties concerned with its provisions, namely transit operating/planning agencies, manufacturers, consultants, engineers, and general interest groups. The application of any recommended practices or guidelines contained herein is voluntary. APTA standards are mandatory to the extent incorporated by an applicable statute or regulation. In some cases, federal and/or state regulations govern portions of a transit system's operations. In cases where this is a conflict or contradiction between an applicable law or regulation and this document, consult with a legal advisor to determine which document takes precedence.*

© 2018 NATSA and its parent organization. No part of this publication may be reproduced in any form, in an electronic retrieval system or otherwise, without the prior written permission of NATSA.

# Table of Contents

Participants.....	iv
Introduction.....	v
<b>1. Electronic Air Brake Systems .....</b>	<b>1</b>
<b>2. Single Car Testing Device and Bleed Cock Arrangement .....</b>	<b>1</b>
2.1 General Description .....	1
2.2 Test Gauge Arrangement .....	3
2.3 Dummy Couplings.....	4
<b>3. Calibration Requirements .....</b>	<b>4</b>
3.1 Single Car Testing Device .....	4
3.2 Ancillary Gauges .....	4
3.3 Record Keeping .....	4
<b>4. General Test Procedures .....</b>	<b>5</b>
4.1 Testing Device Preparation.....	5
4.2 General Information.....	6
<b>5. Car Preparation .....</b>	<b>7</b>
5.1 Safety .....	7
5.2 Car Setup.....	7
<b>6. Test Equipment Installation .....</b>	<b>8</b>
6.1 Connecting the Device to Car .....	8
<b>7. Leakage Tests .....</b>	<b>9</b>
7.1 System Leakage Test .....	9
7.2 Main Reservoir Leakage .....	9
<b>8. Functionality Testing .....</b>	<b>10</b>
8.1 Preparation .....	10
8.2 Service Stability Test .....	10
8.3 Release Testing .....	11
8.4 Application and Release Sensitivity Test.....	12
<b>9. Emergency Brake Application Tests.....</b>	<b>12</b>
9.1 Emergency Test (Auxiliary Venting Portions) .....	12
9.2 Emergency Test (Control Valve/Operating Unit).....	13
9.3 Brake Cylinder Cut-Out Cocks.....	13
9.4 Release Test after Emergency.....	14
<b>10. Leakage Tests—Control Valve and Brake Cylinder .....</b>	<b>14</b>
10.1 Control Valve.....	14
10.2 Brake Cylinder Leakage .....	14
<b>11. Emergency Brake (Conductor’s) Valve Test .....</b>	<b>15</b>
<b>12. Variable Load Control.....</b>	<b>15</b>
12.1 Empty (Light) Car.....	15
12.2 Loaded (Heavy) Car.....	16

<b>13. Miscellaneous Devices</b> .....	<b>16</b>
13.1 Hand Brake/Parking Brake .....	16
13.2 Wheel Slide Protection Equipment .....	17
13.3 Conductor’s Signal System.....	17
13.4 Electropneumatic Operation .....	17
13.5 Ancillary Pneumatic Equipment .....	17
<b>14. Completion of Testing</b> .....	<b>17</b>
14.1 Test Equipment .....	17
14.2 Final Car Preparation .....	17
<b>15. Single Car Test Device—Testing</b> .....	<b>17</b>
15.1 Daily Test for Single Car Testing Device.....	17
15.2 92-day Test for the Single Car Testing Device and Test Coupling .....	18
References.....	26
Definitions.....	26
Abbreviations and acronyms.....	26
Summary of document changes .....	26
Document history .....	28
Annex A – Equipment-Dependent Instructions .....	29

## List of Figures and Tables

Figure 1 Standard Passenger Single Car Testing Device with FLOWRATOR (SPFRS Designation) .....	2
Figure 2 Single Car Testing Device Test Coupling (Passenger) (Part of Device).....	2
Figure 3 Rotary Valve and the Rotary Valve Seat of the Single Car Testing Device.....	3
Figure 4 Test Gauge: Bleed Cock Arrangement .....	4
Figure 5 FLOWRATOR Detail.....	6
Table 1 Required Nominal Values <sup>1</sup> .....	7
Table 2 Brake System Cock Positions .....	8
Table 3 Test Procedures.....	18
Figure 6 Standard Rack for Testing Passenger Single Car Testing Device .....	19
Figure 7 Alternate Rack for Testing the Passenger Single Car Testing Device .....	22
Table 4 Equipment-Dependent Instructions .....	29



## Participants

The American Public Transportation Association greatly appreciates the contributions of the members of the **Mechanical Brake Sub-Working Group of the PRESS Mechanical Working Group**, who provided the primary effort in the drafting of the latest revision of this document:

**Paul Jamieson**, SNC-Lavalin Rail & Transit, *Chair*

B.A. Black, *Virginkar & Associates*  
James Dewberry, *Wabtec Corporation*  
Adam Eby, *AMTRAK*  
Kenneth Hesser, *LTk Engineering Services*  
William Jubeck, *Pittsburgh Air Brake*  
Andrew Long, *CH2M*

Bryan McLaughlin, *New York Air Brake*  
Allen Nutt, *LTk Engineering Services*  
George Payne, *PDI Rail Solutions*  
Danial Rice, *Wabtec Corporation*  
Ron Truitt, *AMTRAK*  
Steven Zuiderveen, *FRA*

At the time this standard was revised, the **Mechanical Working Group** included the following members:

**David Warner**, SEPTA, *Chair*

Allen Bieber, *ACB RailTech Services*  
Brad Black, *Virginkar & Associates*  
Greg Blasco, *West Coast Express*  
Stephen Bonina, *WSP | Parsons Brinckerhoff*  
Glenn Brandimarte, *ORX Rail*  
Tony Brown, *MTA of Harris County*  
Michael Burshtin, *AMTRAK*  
Gordon Campbell, *Crosslinx Transit Solutions*  
Kevin Carmody, *STV Incorporated*  
Steve Chrismer, *LTk Engineering Services*  
John Condrasky, *Wabtec Corporation*  
Joshua Coran, *Talgo*  
Brendan Crowley, *New York Air Brake*  
Richard Curtis, *Curtis Engineering Consulting*  
Steven Dedmon, *Standard Steel*  
James Dewberry, *Wabtec Corporation*  
Joe Di Liello, *VIA Rail Canada*  
Matthew Dick, *ENSCO*  
Adam Eby, *AMTRAK*  
Gary Fairbanks, *FRA*  
Robert Festa, *MTA Long Island Rail Road*  
Steve Finegan, *SNC-Lavalin Rail & Transit*  
Gavin Fraser, *CH2M*  
Jeff Gordon, *American Truck Wash Systems*  
Jeffrey Gordon, *Volpe*  
Mark Hartong, *FRA*  
James Herzog, *LTk Engineering Services*  
Kenneth Hesser, *LTk Engineering Services*

Christopher Holliday, *STV Incorporated*  
George Hud, *LTk Engineering Services*  
Paul Jamieson, *SNC-Lavalin Rail & Transit*  
John Janiszewski, *LTk Engineering Services*  
Kevin Kesler, *FRA*  
Peter Klauser  
Heinz-Peter Kotz, *Siemens AG*  
Tammy Krause, *AMTRAK*  
Pallavi Lal, *LTk Engineering Services*  
Peter Lapre, *Volpe*  
Nicolas Lessard, *Bombardier Transportation*  
Cameron Lonsdale, *Standard Steel*  
Francesco Maldari, *MTA Long Island Rail Road*  
Brian Marquis, *Volpe*  
Eloy Martinez, *LTk Engineering Services*  
Raynald Masse, *AMT*  
Robert May, *LTk Engineering Services*  
Ronald Mayville, *Simpson Gumpertz & Heger*  
Richard Mazur, *Wabtec Corporation*  
Bryan McLaughlin, *New York Air Brake*  
Luke Morscheck, *LTk Engineering Services*  
Allen Nutt, *LTk Engineering Services*  
Chris Nuttall, *Thales*  
Paul O'Brien, *First Transit*  
John Pearson, *LTk Engineering Services*  
Martin Petzoldt, *Railroad Friction Products*  
Ian Pirie, *STV Incorporated*  
Danial Rice, *Wabtec Corporation*

Steven Roman, *LTK Engineering Services*  
Carol Rose, *STV Incorporated*  
Thomas Rusin, *Rusin Consulting Corporation*  
Mehrdad Samani, *CH2M*  
Martin Schroeder, *CH2M*  
Richard Seaton, *TDG Transit Design Group*  
Patrick Sheeran, *LTK Engineering Services*  
Melissa Shurland, *FRA*

Mark Stewart, *SNC-Lavalin Rail & Transit*  
Narayana Sundaram, *ENSCO*  
Ali Tajaddini, *FRA*  
Jeff Thompson, *SEPTA*  
Ronald Truitt, *AMTRAK*  
Brian Whitten, *SNC-Lavalin Rail & Transit*  
Todd Williams, *Penn Machine Company*  
Gregory Yovich, *NICTD*

### **Project team**

Narayana Sundaram, *American Public Transportation Association*  
Nathan Leventon, *American Public Transportation Association*

## **Introduction**

*This introduction is not part of APTA PR-M-S-005-98, Rev. 4, “Code of Tests for Passenger Car Equipment Using Single Car Testing.”*

This standard applies to all:

- Railroads that operate intercity or commuter passenger train service on the general railroad system of transportation; and
- Railroads that provide commuter or other short-haul rail passenger train service in a metropolitan or suburban area, including public authorities operating passenger train service.

This standard does not apply to:

- Rapid transit operations in an urban area that are not connected to the general railroad system of transportation;
- Tourist, scenic, historic, or excursion operations off the general railroad system of transportation;
- Operation of private cars, including business/office cars and circus trains unless otherwise required by other standards or regulations; or
- Railroads that operate only on track inside an installation that is not part of the general railroad system of transportation.

**NOTE:** For this standard, pressures associated with 110 psi operation are shown first in **BOLD**, followed by the corresponding pressure used with 90 psi service. Example: **110 psi** (90 psi).

# Code of Tests for Passenger Car Equipment Using Single Car Testing

## 1. Electronic Air Brake Systems

1.1 Electronic Air Brake (EAB) systems refer to microprocessor based electronic service brake control of brake cylinder pressure.

1.2 EAB systems may employ self-test features and/or runtime diagnostics that validate functions. If self-test features are used to validate the system, then the operator shall provide a matrix identifying which sections of PR-M-S-005-98 are addressed by the application of the self-test function. Justification for self-test validation equivalence shall be provided.

1.2.1 Electronic record of successful self-test results shall be available for inclusion in the overall car test record.

1.3 Cars equipped with EAB control systems shall be tested in both normal and backup modes. Functions not influenced by the powered state of the brake system require testing in only one state (normal or back-up) for validation.

1.3.1 Normal mode is defined as the EAB system being powered and active with microprocessors controlling and monitoring the functionality of the system.

1.3.2 Back-up mode is defined as the EAB system in an un-powered state with only pneumatic functionalities.

## 2. Single Car Testing Device and Bleed Cock Arrangement

**NOTE:** The Single Car Testing Device used shall conform to the requirements of this standard. The Device shall be equipped with a FLOWRATOR, reducing valve and strainer.

**NOTE:** When testing equipment at 110 psi brake pipe pressure, the Single Car Testing Device shall be equipped for 110 psi operation. A kit for upgrading a Single Car Test Device can be acquired from the Single Car Testing Device manufacturer.

### 2.1 General Description

There are two types of the Single Car Testing Device, which are similar in appearance. One is for passenger cars and the other for freight cars. The Devices are identified by nameplates, which are marked “SPFRS” for a passenger Single Car Testing Device or “SFFRS” for a freight Single Car Testing Device. It is required to use the correct Single Car Testing Device for the type of brake equipment being tested.

Throughout this standard, the Single Car Testing Device shall be referred to as the “Device.” The Device is shown in **Figure 1**. Detail of the Single Car Testing Device Test Coupling is shown in **Figure 2**. The Rotary Valve and Rotary Valve Seat are shown in **Figure 3**.

**FIGURE 1**

Standard Passenger Single Car Testing Device with FLOWRATOR (SPFRS Designation)

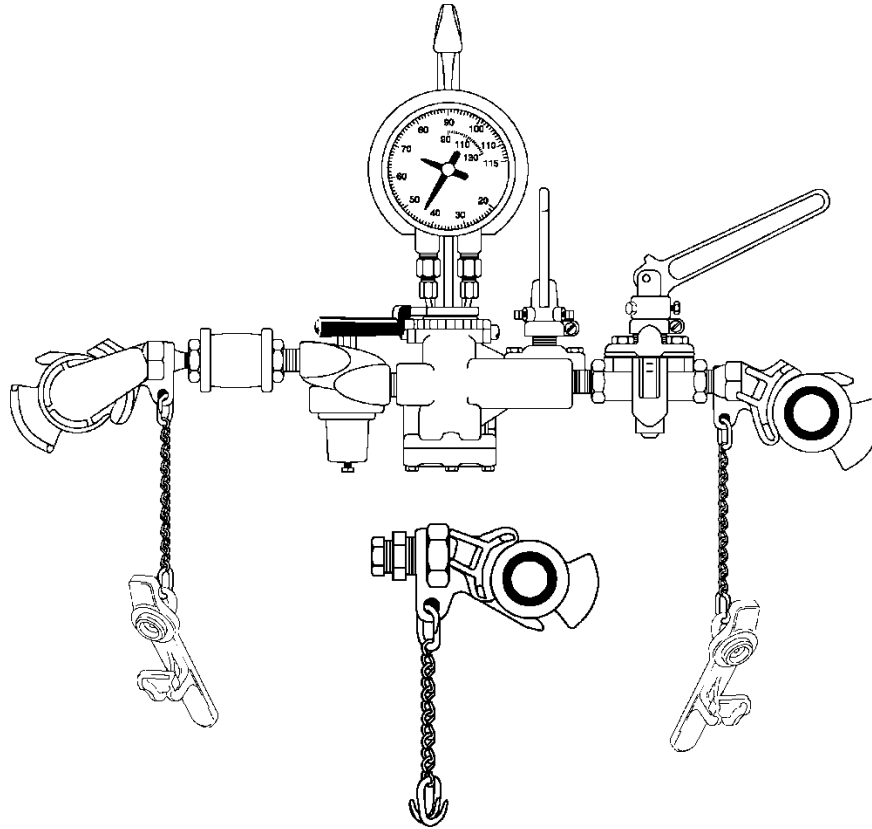

**FIGURE 2**

Single Car Testing Device Test Coupling (Passenger) (Part of Device)

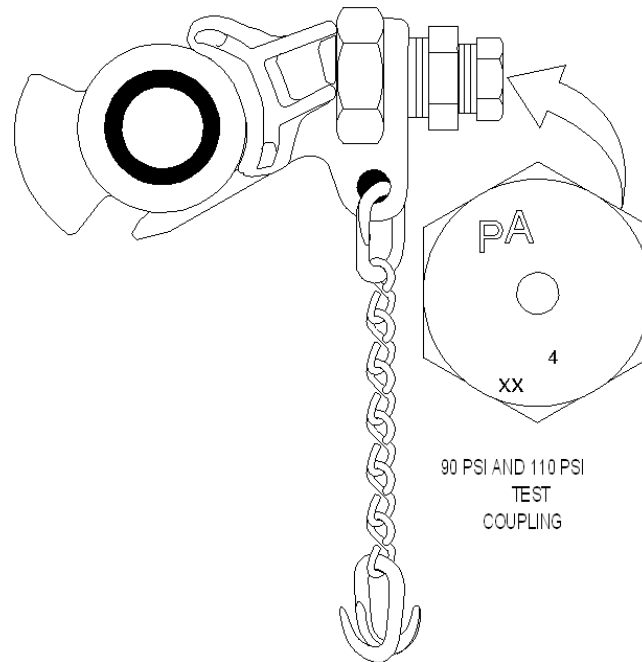

**FIGURE 3**  
Rotary Valve and the Rotary Valve Seat of the Single Car Testing Device

Positions of Standard Passenger Single Car Testing Device	
Position No. 1	MR charges brake pipe through 0.250 in. (¼ in. drill) opening
Position No. 2	MR charges brake pipe through 0.0225 in. (No. 74 drill) opening
Position No. 3	Lap
Position No. 4	Brake pipe pressure reduces through 0.0465 in. (No. 56 drill) opening
Position No. 5	Brake pipe pressure reduces through 0.09375 in. (¾ <sub>32</sub> in. drill) opening
Position No. 6	Brake pipe pressure reduces through 0.1875 (¾ <sub>16</sub> in. drill) opening
¾ in. Test Device Cock	Brake pipe pressure reduces through 0.375 in. (¾ in. drill) opening

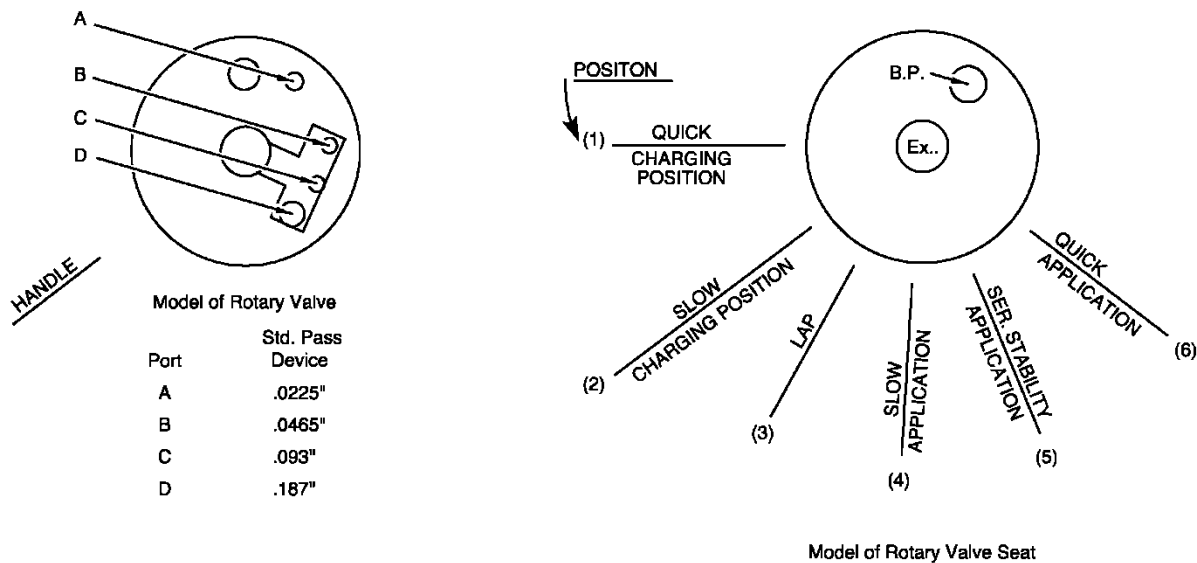

## 2.2 Test Gauge Arrangement

**2.2.1** All gauges used during the following tests shall be an ASME Grade 2A gauge or equivalent as specified by ASME B40.1 or ASME B40.7. The recommended span of the gauge for measuring brake pipe pressure and main reservoir pressure is 200 psi. When measuring brake cylinder pressure or brake cylinder control pressure, the recommended span of the gauge is 100 psi.

**2.2.2** The typical gauge arrangements consist of either a gauge or gauge with bleed cock, connected to a short length of hose and the appropriate equipment interface fitting (flange, test point, pipe tap, etc.). The equipment interface fittings shall provide an airtight seal and should be checked whenever leakage is detected during the test. Use the correct interface fitting for each test gauge connection as determined by the equipment manufacturer/operating authority. **Figure 4** shows a typical test gauge with bleed cock and pipe thread/flange fitting.



**FIGURE 4**  
Test Gauge: Bleed Cock Arrangement

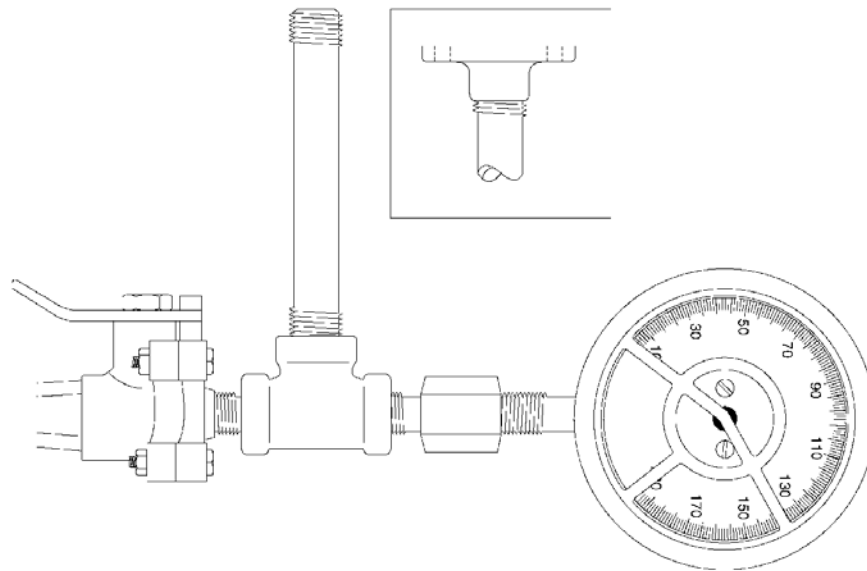

## 2.3 Dummy Couplings

2.3.1 One “F” type non-vented dummy coupling (brake pipe) and one “L” type non-vented dummy coupling (Main Reservoir) are required.

## 3. Calibration Requirements

### 3.1 Single Car Testing Device

To secure reliable and uniform results with the Single Car Testing Device, it shall be kept free from leakage and tested daily before use (see Section 15.1 for Daily Test). The Device shall not be used if it exceeds 92 days from first being placed in service. After 92 days of being in service, the Device shall be tested per Section 15.2. The Device may not be used in service if it exceeds 368 days from its last Section 15.2 test. Once every 368 days, the Device must be completely disassembled, cleaned and tested per manufacturer’s recommendations.

**NOTE:** The Single Car Testing Device shall be verified as a Passenger Type Single Car Testing Device (SPFRS) and properly marked as such.

### 3.2 Ancillary Gauges

The gauges shall be calibrated after 92 days from first being placed in service and may not be used in service if they exceed 368 days from the date of last calibration. Electronic pressure gauges shall be calibrated at least once every 368 days.

### 3.3 Record Keeping

3.3.1 Single Car Testing Device and Ancillary Gauges shall be dated when last tested or calibrated per Section 15.2.

3.3.2 After being placed in service, the Single Car Testing Device and Ancillary Gauges must be tagged or labeled with the next due date for testing or calibration per Section 15.2.

## 4. General Test Procedures

### 4.1 Testing Device Preparation

4.1.1 The Single Car Testing Device shall be maintained in accordance with Section 15.

4.1.2 The Daily Test as specified in Section 15.1 shall be performed prior to using the Device on that day.

4.1.2.1 A source of clean, dry air shall be maintained at **120 psi** (100 psi) minimum to the Device during test for proper operation and results. An efficient air filter in the supply line ahead of the regulating valve shall be installed. Before the Device is attached to the supply line, the line shall be blown out.

4.1.2.2 Between the Device and the outlet hose coupling, which connects to the brake pipe hose on the car, the use of a hose is optional. If used, such outlet hose shall be of  $\frac{3}{4}$  in. size with  $\frac{1}{2}$  in. connecting nipples and not greater than 8 ft. in length. A flat (roll-up) hose may be used to connect the Device to the car being tested; however, no kinks are allowed in the hose at any time during the test.

4.1.2.3 FLOWRATOR tube shall be within 15 deg. of vertical.

4.1.2.4 The Device ends, Device exhausts and test coupling shall be protected from contamination (entry of dirt).

4.1.2.5 The tests are to be made with the Device reducing valve adjusted for **110 psi** (90 psi).

4.1.3 Care should be exercised in moving the Device handle back to Position No. 3 (Lap) after making brake pipe reductions of 15 psi or more in Position No. 5 and Position No. 6. When the handle is snapped back, the temperature effect may cause the brake pipe pressure to rise  $1\frac{1}{2}$  to 2 psi and may be the cause of an undesired release. The Device handle should be moved slowly toward Lap position.

4.1.4 When making tests of cars having two sets of brake equipment, each set shall be tested separately, with the branch pipe Cut-Out Cock closed to one set while the other set is being tested.

4.1.5 In the event of the valve failing to pass the specified test, it shall be ascertained that the Device and any test gauge attachments are not at fault.

4.1.6 To determine a “fully charged system” using the FLOWRATOR, move the Device handle into Position No. 1 and close the FLOWRATOR by-pass cock. If the ball remains below the condemning line (refer to 4.1.6.2) of the FLOWRATOR tube, then the system is fully charged. Open the FLOWRATOR by-pass cock. If the ball rises above the condemning line of the FLOWRATOR tube, then the system is not fully charged or the system has excess leakage. Open the FLOWRATOR by-pass cock and allow the system to continue charging, or assess potential leakage sources.

4.1.6.1 For equipment that uses equalization of the brake cylinder supply reservoir to the brake cylinders, a longer time period may be required to properly charge the control reservoir even if the FLOWRATOR ball is below the condemning line.

4.1.6.2 When using a FLOWRATOR calibrated for both 110 psi and 90 psi brake pipe, use the upper condemning (Red) line for 90 psi brake pipe and the lower (Black) line for 110 psi brake pipe, as shown in **Figure 5**.

**FIGURE 5**  
FLOWRATOR Detail

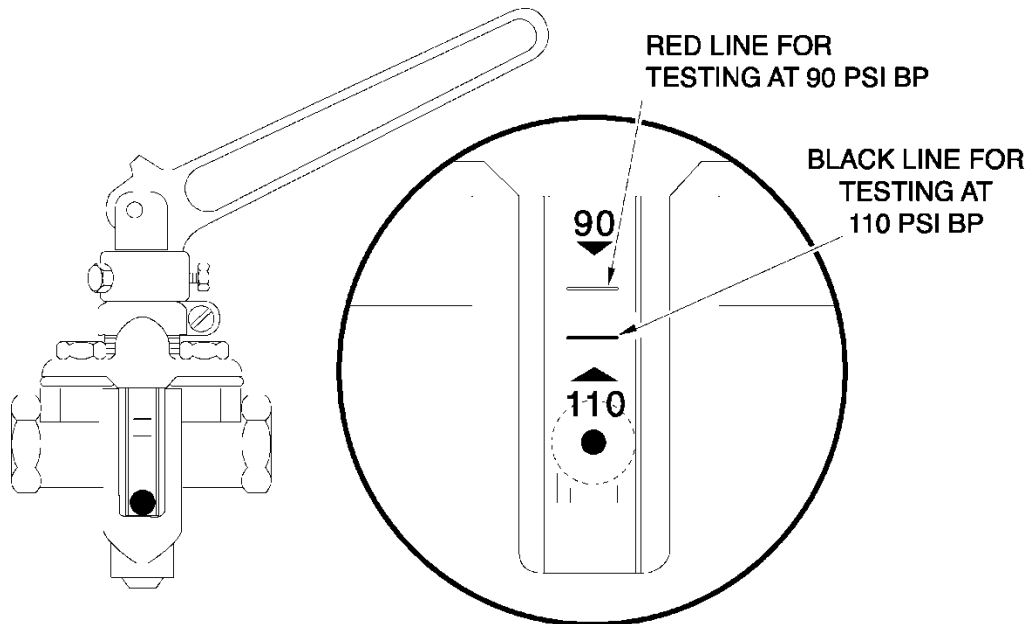

**4.1.7** If using a Device when the FLOWRATOR has been disqualified by the daily test in Section 15.1, the determination of a “fully charged system” shall be performed as follows:

**4.1.7.1** Move the Device handle to Position No. 3 (Lap). If the brake pipe pressure decreases more than 1 psi in 1 minute, then the system is not fully charged or the system has excess leakage. Move the Device handle to Position No. 1 and continue charging or assess potential leakage sources.

## **4.2 General Information**

**4.2.1** As used in this standard, pounds per square inch (psi) shall indicate pressure as pounds per square inch gauge (psig) unless otherwise specified. The pressure measured is greater than ambient using ambient pressure as the reference.

**4.2.2** As used in this standard, “brake cylinder” refers to all components connected to the brake cylinder line, including but not limited to the brake cylinder piping, tread brake units, disc brake units, brake cylinder indicators and wheel slide protection equipment.

**4.2.3** As used in this standard, the term “Cut In” (OPEN) will be used to designate a cut-out cock that will allow the passage of air between equipment components. The term “Cut Out” (CLOSED) will be used to designate a cut-out cock that will prevent or stop the flow of air between equipment components.

**4.2.4** Any ancillary equipment not identified or provided a test procedure with this standard shall be tested in accordance with equipment manufacturer/operating authority instructions, as described in Section 13.5.

**4.2.5** Passenger cars equipped with freight-based brake systems shall be tested using equipment manufacturer/operating authority approved procedures in accordance with current Federal Regulations.

**APTA PR-M-S-005-98, Rev. 4**  
**Code of Tests for Passenger Car Equipment Using Single Car Testing**

**4.2.6** When a car is equipped with a main reservoir pipe, air pressure of **120 psi** (100 psi) minimum should be connected to the main reservoir trainline as instructed in the standard. The dual air source arrangement (brake pipe and main reservoir) will aid in reducing the test time and will not compromise test results.

**4.2.7** Tests of car equipment shown herein may be performed in a different order than listed in this procedure, provided that the conditions for the test and the performance criteria described are adhered to.

**4.2.8** The nominal values shown in **Table 1** need to be obtained from the operating authority for use in testing:

**TABLE 1**  
 Required Nominal Values<sup>1</sup>

	Air Spring Pressure	Brake Cylinder Pressure <sup>2</sup>	
		Service	Emergency
Non-Load-Weigh	0 <sup>3</sup>	X <sup>4</sup>	X <sup>4</sup>
Empty (Light)			
Loaded (Heavy) <sup>5</sup>			

1. Nominal values represent the normal values that are obtainable on an “in-date” car. These values should be obtained from the equipment manufacturer/operating authority.
2. For equipment that uses equalization, the brake cylinder pressure tolerance shall be ±5 psi. This tolerance is based on volume variations in car piping.
3. Zero (0) Air Spring Pressure is used for cars not equipped with a load weigh system or the brake cylinder pressure when load weigh is Cut Out (Not Operating).
4. Only these pressures are required for cars not equipped with a load weigh system.
5. Loaded (Heavy) car air spring pressure shall be higher than the Empty (Light) car pressure such that the Loaded car brake cylinder pressure minus tolerance does not overlap the Empty car brake cylinder pressure plus tolerance. Heavy car air spring pressure does not have to be equivalent to maximum loaded pressure of the car.

## 5. Car Preparation

### 5.1 Safety

**5.1.1** Chock wheels to prevent car movement during tests.

**5.1.2** Follow car testing safety regulations of the operating authority.

### 5.2 Car Setup

**5.2.1** Open cut-out cock(s) between the Main Reservoir and Air Spring system (if equipped).

**5.2.2** Ensure that the hand brake/parking brakes are released where applicable.

**5.2.3** If testing a cab car, the cab equipment details shall be conditioned so that the car brake equipment functions as a trailer car. Refer to equipment manufacturer/operating authority procedures for conditioning cab car equipment. Locomotive functions (service control of brake pipe) of cab cars shall be tested per current FRA regulations.

**5.2.4** Water raising equipment should be Cut Out at the water filling valves or other appropriate locations as instructed by equipment manufacturer/operating authority.

**APTA PR-M-S-005-98, Rev. 4**  
**Code of Tests for Passenger Car Equipment Using Single Car Testing**

**5.2.5** Other ancillary equipment connected to the Main Reservoir shall be Cut Out. (See Section 13.5 for testing ancillary equipment.)

**5.2.6** The brake system cocks shall be placed in the appropriate positions as listed in **Table 2** before testing begins.

**TABLE 2**  
Brake System Cock Positions

Brake System Cocks	Position
Brake Pipe and Main Reservoir (If equipped) trainline cocks	OPEN
Brake Pipe Branch Pipe Cut-Out Cock	Cut In
All equipment cocks attached to Brake Pipe	Cut In
Brake Cylinder (Truck Cut-Out)	Cut In

**SAFETY WARNING:** Ensure that no air is on the car before making any of the following gauge connections. Plugs or blanking plates shall be carefully loosened before they are removed in order to minimize the possibility of personal injury from the effects of residual, pressurized air that may be in the equipment components.

**5.2.7** Connect ASME Grade 2A gauge to the test points of the following: main reservoir trainline (if equipped), brake cylinder, control valve exhaust (10 port),\* relay valve exhaust,\* and load weigh (air spring) system (if equipped). A single gauge may be used but shall be moved between each test point during the testing procedures as required. The bleed cocks shall remain cut in (open) on the control valve and relay valve exhausts before beginning and throughout the procedures outlined in this standard unless otherwise instructed.

**NOTE:** For components marked with an asterisk (\*), test gauge shall include a bleed cock to properly perform tests.

**5.2.8** An ASME Grade 2A gauge may be connected to 16 pipe if desired by the operating authority to aid in testing.

## **6. Test Equipment Installation**

### **6.1 Connecting the Device to Car**

**SAFETY WARNING:** Care should be taken that all supply air is cut out to prevent any whipping or lashing of hoses and couplings. Make certain that all test gauges and the Device are fastened and/or connected securely to minimize the possibility of personal injury from parts that may be “blown” from the test arrangement when air is admitted to the Device or brake equipment.

**6.1.1** Close the branch pipe cut-out cock on the car and ensure that all reservoirs are completely drained. All reservoir drain cocks should be closed.

**6.1.2** Connect the Device end marked B.P. to the brake pipe hose at one end of the car (preferably the B end of the car).

**6.1.3** Connect the supply line to the end of the Device near the reducing valve.

**APTA PR-M-S-005-98, Rev. 4**  
**Code of Tests for Passenger Car Equipment Using Single Car Testing**

**6.1.4** Make sure that the FLOWRATOR by-pass cock is open and that both angle cocks are open. Open the supply air cut-out cock.

**6.1.5 TEST:** Move the Device handle to Position No. 1. A continuous flow of air must occur from the open brake pipe hose at the opposite end of the car.

**6.1.6** Close the brake pipe angle cock at the end opposite of the Device, and couple on a non-vented “F” type dummy hose coupling. Reopen the brake pipe angle cock slowly while holding the end hose to control movement.

**NOTE:** For cars not equipped with a main reservoir trainline, proceed to Section 7.

**6.1.7** Close all drains and cutout cocks of main reservoir trainline.

**NOTE:** Make sure main reservoir trainline gauge is not isolated.

**6.1.8 TEST:** With a gauge connected to the main reservoir (MR) trainline, monitor the MR trainline pressure. MR trainline pressure shall not increase in 3 minutes.

**6.1.9** Open MR trainline end cut-out cocks as necessary.

**6.1.10** Continue charging the brake pipe and reservoirs to **110 psi** (90 psi).

## **7. Leakage Tests**

### **7.1 System Leakage Test**

**7.1.1 TEST:** Close the FLOWRATOR by-pass cock. If the ball is not above the condemning line, then open the FLOWRATOR by-pass cock and proceed directly to Section 7.2, “Main Reservoir Leakage” (if equipped). If any part of the ball is above the condemning line, then make a complete check for leakage (with soap suds when weather conditions permit) of all pipes and pipe connections, including angle cocks, hoses, check valves and auxiliary components.

**7.1.2** If leakage is found, then make repairs necessary to reduce it to where the ball of the FLOWRATOR stays below the condemning line. Then open the FLOWRATOR by-pass cock and proceed to Section 7.2, “Main Reservoir Leakage” (if equipped).

### **7.2 Main Reservoir Leakage**

**NOTE:** For cars not equipped with a main reservoir trainline, proceed to Section 8.

**NOTE:** The air supplied to the main reservoir pipe shall be taken from the supply side of the Device or an alternate air supply line. Before making any hose connection, the supply line shall be blown out.

**7.2.1** With a gauge connected to the main reservoir trainline and the test air supply cut-out cock closed, make a connection of a **120 psi** (or **100 psi** if testing a car with a main reservoir pass-through pipe) minimum supply air (air shall be from a clean, dry source) to the main reservoir pipe hose at one end of the car.

**7.2.2 TEST:** With both main reservoir trainline cocks open, partially open the test air supply cut-out cock and note the continuous flow of air from the main reservoir hose opening at the opposite end of the car.

**7.2.3** Close the main reservoir trainline cock at the end of the car opposite the test supply air connection.

**APTA PR-M-S-005-98, Rev. 4**  
**Code of Tests for Passenger Car Equipment Using Single Car Testing**

**7.2.4** Connect a non-vented “L” type dummy hose coupling to the main reservoir pipe hose coupling and open the main reservoir trainline cock.

**7.2.5** Open the main reservoir test air supply cock and charge the main reservoir system.

### **7.2.6 Main Reservoir Leakage (non pass-through)**

**NOTE:** For cars equipped with a main reservoir pass-through pipe, proceed to Section 7.2.7.

**7.2.6.1** Move the Device handle to Position No. 5, and make a 10 psi reduction in brake pipe. Move the Device handle into Position No. 3 (Lap).

**7.2.6.2 TEST:** After 30 seconds, observe the Device gauge. Pressure increase shall not exceed 3 psi in 1 minute and shall stabilize.

**7.2.6.3** Close the main reservoir test air supply cock.

**7.2.6.4 TEST:** Observe the main reservoir gauge. Pressure decrease shall not exceed 5 psi in 1 minute.

**7.2.6.5** Open the main reservoir test air supply cock, move the Device handle to Position No. 1 and fully charge the brake equipment.

**7.2.6.6** Proceed to Section 8.

### **7.2.7 Main Reservoir Leakage (pass-through)**

**NOTE:** “Pass-Through” means no pneumatic equipment connected to the pipe.

**7.2.7.1** Pressurize the Main Reservoir pipe to 100 psi minimum and close air supply cut-out cock.

**7.2.7.2 TEST:** After 30 seconds, observe the main reservoir gauge. Pressure decrease shall not exceed 5 psi in 1 minute and shall stabilize.

## **8. Functionality Testing**

### **8.1 Preparation**

**8.1.1** Cars equipped with a pneumatic cutoff valve controlling the load weigh system shall either temporarily disable the variable load valve or inhibit its operation. The air spring pressure shall be reduced a minimum of 10 psi below the Light (Empty Car) air spring pressure.

**NOTE:** Some variable load valve arrangements may require that the air spring pressure be reduced to zero (0) psi for proper determination of the non-load-weigh brake cylinder pressure. Check with the equipment manufacturer/operating authority for details on preparation of equipment for this test.

### **8.2 Service Stability Test**

**8.2.1** Confirm installation of an air gauge in the brake cylinder line. With the equipment fully charged, move the Device handle to Position No. 5, reducing brake pipe pressure 27 psi, and then slowly move handle to Position No. 3 (Lap).

**8.2.2 TEST:** This test shall not produce an emergency application.

**8.2.3 TEST:** Allow 20 seconds for the brake cylinder gauge to stabilize. Observe the brake cylinder gauge, and verify that the non-load weigh service brake cylinder pressure  $\pm$  3 psi as specified is correct. Then note that brake cylinder pressure increases no more than 3 psi in 1 minute.

### **8.3 Release Testing**

Cars shall be tested for Direct and/or Graduated release based on the type of service in which the car is intended to be used. Intended service is that service in which the car is operated in an ongoing basis between prescribed single car testing intervals. If a car's brake release configuration is required to change from direct to graduated or graduated to direct to meet the train operating requirements, then the brake equipment must be tested in graduated and direct release configurations.

**CAUTION:** When changing the Graduated/Direct Release Cap or other related covers, refer to the equipment manufacturer/operating authority instructions.

For cars equipped with an EAB system release, testing shall be tested in both normal and back-up mode in accordance with equipment manufacturers/operating authority procedures.

#### **8.3.1 Direct Release Test**

**NOTE:** For cars operated in Direct release service, ensure that the Graduated/Direct release cap is in the Direct release position. Cars operated only in Graduated release service shall have the Graduated/Direct release cap left in the Graduated release position.

For cars operated only in graduated release service, proceed to Section 8.3.2.

**8.3.1.1 TEST:** With a 27 psi brake pipe reduction in effect, move the Device handle to Position No. 1 until brake pipe pressure has increased 10 to 11 psi; then move handle to Position No. 3 (Lap) and note that brake cylinder control (port 10 exhaust) pressure shall fully exhaust.

**8.3.1.2** Move the Device handle to Position No. 1 to fully recharge the brake pipe and reservoirs. Check that the equipment is fully charged and the brakes are released.

#### **8.3.2 Graduated Release Test**

For cars operated only in direct release service, proceed to Section 8.4.

**NOTE:** Cars operated only in Graduated release service or cars operated in both Graduated and Direct release service shall be tested in the manner described by this section. Ensure that the Graduated/Direct release cap is placed in the Graduated position before proceeding with this section.

**NOTE:** Cars equipped with variable load control systems shall be tested in the Loaded (Heavy) Car condition.

**CAUTION:** When changing the Graduated/Direct Release Cap or other related covers, refer to the equipment manufacturer/operating authority instructions.

**8.3.2.1** Move the Device handle to Position No. 1 to fully recharge the brake pipe and reservoirs.

**8.3.2.2** Make a 27 psi brake pipe reduction, and then move the Device handle to Position No. 3 (Lap).



**8.3.2.3 TEST:** Move the Device handle to Position No. 1 until brake pipe pressure has increased 8 to 9 psi; then move the Device handle to Position No. 3 (Lap). Brake cylinder control (port 10 exhaust) pressure shall partially exhaust and stabilize.

**8.3.2.4 TEST:** Move the Device handle to Position No. 1 until brake pipe pressure has increased 3 to 4 psi; then move the Device handle to Position No. 3 (Lap). Brake cylinder control (port 10 exhaust) pressure shall partially exhaust and stabilize.

**8.3.2.5 TEST:** Repeat Section 8.3.2.4.

**8.3.2.6** Move the Device handle to Position No. 1 to fully recharge the brake pipe and reservoirs.

## **8.4 Application and Release Sensitivity Test**

**NOTE:** For PS-68 Type brake equipment, a 10 psi reduction is required.

**8.4.1** With the equipment fully charged, move the Device handle to Position No. 5 until a 5 psi brake pipe reduction is obtained; then slowly move the handle to Position No. 3 (Lap). The brake pipe pressure shall continue to drop to within a **104 psi** (84 psi) maximum and a **100 psi** (80 psi) minimum allowable pressure range. If brake pipe pressure stabilizes between **100 psi** (80 psi) and **104 psi** (84 psi), then proceed to Section 8.4.2.

**8.4.1.1** If brake pipe reduction continues after the Device handle is placed in Position No. 3, then move the Device handle to Position No. 2 until the brake pipe pressure stops reducing. Then immediately move the Device handle back to Position No. 3 (Lap).

**NOTE:** Brake Pipe pressure reduction must not reduce past **94 psi** (74 psi) while in Position No. 2. If Brake Pipe reduces past **94 psi** (74 psi) then repeat Section 8.4.1.

**8.4.2 TEST:** Allow 20 seconds for the brake cylinder gauge to stabilize. The brake cylinder pressure shall not increase/decrease more than 3 psi in 1 minute.

**NOTE:** During the Release Sensitivity Test, the reducing valve supply pressure shall not decrease more than 2 psi.

**8.4.3** Move the Device handle to Position No. 2.

**8.4.4 TEST:** Brake cylinder pressure shall begin to decrease within 90 seconds as indicated by an exhaust of air from the 16 pipe exhaust (port 10 or equivalent) or by a reduction of brake cylinder measured at the brake cylinder gauge.

**8.4.5** Continue the test until brake cylinder pressure is zero (0) psi and brake shoes/pads are fully released from the braking surfaces as defined by the equipment manufacturer/operating authority.

**8.4.6** Move the Device handle to Position No. 1 and fully recharge the brake system.

## **9. Emergency Brake Application Tests**

### **9.1 Emergency Test (Auxiliary Venting Portions)**

**NOTE:** The following test shall be individually performed for each auxiliary venting portion on the car. Portions not being tested shall be Cut Out/Plugged.

**APTA PR-M-S-005-98, Rev. 4**  
**Code of Tests for Passenger Car Equipment Using Single Car Testing**

**9.1.1** Plug all auxiliary brake pipe emergency venting portions except the one being tested.

**9.1.2** Verify that the system is fully charged. Move the Device handle to Position No. 5 and make a 27 psi reduction in brake pipe pressure. Move the Device handle to Position No. 3 (Lap).

**9.1.3** Cut Out/Plug the control valve/operating unit emergency venting portion.

**9.1.4 TEST:** With the Device handle in Position No. 3 (Lap), open the Device  $\frac{3}{8}$  in. cock. This test shall produce an emergency reduction as indicated by the opening of the auxiliary venting portion and the sudden decrease in brake pipe pressure.

**9.1.5** Close the Device  $\frac{3}{8}$  in. cock.

**9.1.6** If this is the last auxiliary venting portion to be tested, install a plug in the tested portion; then proceed to Section 9.1.8. Otherwise install a plug in the tested valve and remove the plug from the next device to be tested.

**9.1.7** Move the Device handle to Position No. 1 and recharge equipment. Proceed to Section 9.1.2 to test the remaining auxiliary venting portions.

**9.1.8** Cut In/unplug the control valve/operating unit emergency venting portion.

**9.1.9** Move the Device handle to Position No. 1 to fully recharge brake pipe and reservoirs.

## **9.2 Emergency Test (Control Valve/Operating Unit)**

**NOTE:** This section applies only if the control valve/operating unit includes a feature for brake pipe emergency venting.

**9.2.1** Verify that all auxiliary venting portion(s) are plugged.

**9.2.2** With the equipment fully charged, move the Device handle to Position No. 5 and make a 27 psi reduction in brake pipe pressure. Move the Device handle to Position No. 3 (Lap).

**9.2.3 TEST:** Open the Device  $\frac{3}{8}$  in. cock. This test shall produce an emergency application as indicated by opening of the control valve/operating unit emergency venting portion and the sudden decrease in brake pipe pressure.

**9.2.4 TEST:** Allow 20 seconds for the brake cylinder gauge to stabilize. Observe brake cylinder gauge, and verify that the non-load weigh emergency brake cylinder pressure  $\pm 3$  psi (or equalization pressure) as specified is correct.

**9.2.5** Remove plugs from all emergency venting portions, and install all vent protectors.

## **9.3 Brake Cylinder Cut-Out Cocks**

**NOTE:** If car is equipped with remote handles on the brake cylinder cut-out cocks, then ensure proper operation of the remote handles during this test.

**9.3.1 TEST:** With the brakes applied at emergency brake cylinder pressures, close one brake cylinder cut-out cock and verify that the associated brakes release as indicated by the release of the brake shoes/pads from the

braking surfaces as defined by the equipment manufacturer/operating authority. Also verify the proper operation of any brake cylinder pressure indicators (including illuminated indicators).

**9.3.2** Open brake cylinder cut-out cock.

**9.3.3** Repeat item 9.3.1 for each brake cylinder cut-out cock on the car.

## **9.4 Release Test after Emergency**

**9.4.1 TEST:** At the completion of the Emergency Tests, close the Device  $\frac{3}{8}$  in. cock. Verify that brake pipe pressure on the Device gauge does not increase for 2 minutes.

**9.4.2** Move the Device handle to Position No. 1 and recharge the equipment.

## **10. Leakage Tests—Control Valve and Brake Cylinder**

### **10.1 Control Valve**

For cars equipped with EAB systems, control valve leakage or equivalent shall be tested per equipment manufacturer/operating authority procedures.

**10.1.1** Verify connection of the gauge to the control valve exhaust (26-C 10 port) and close the bleed cock.

**10.1.2** With the equipment fully charged, reduce brake pipe pressure 27 psi in Position No. 5 and then move the Device handle to Position No. 1. If test gauge indicates a pressure in excess of 50 psi, then the pressure shall be reduced to 50 psi through the bleed cock.

**NOTE:** If the control valve exhaust (10 port) gauge pressure does not exceed 50 psi, then test leakage at the pressure obtained.

**10.1.3 TEST:** Observe the test gauge for leakage from the combined volumes of the relay valve diaphragm chamber, 16 pipe/10 port (if used) and their related piping, which shall not exceed 2 psi in 1 minute.

**10.1.4** Open the bleed cock on 10 port.

### **10.2 Brake Cylinder Leakage**

**NOTE:** If the car is not equipped with a brake cylinder relay valve, proceed to Emergency Brake (Conductor's Valve Test) Section 11.

EAB systems utilizing electronic brake cylinder control shall provide a means of isolating the electronic brake cylinder control from maintaining brake cylinder pressure.

**10.2.1** Verify connection of the gauge to the relay valve exhaust or brake cylinder line.

**10.2.2** With the equipment fully charged, reduce brake pipe pressure 27 psi in Position No. 5, and then slowly move the Device handle to Position No. 3 (Lap).

**10.2.3** Close the bleed cock on the test gauge or isolate the brake cylinder pressure maintaining from the brake cylinder control valve.

**10.2.4** Move the Device handle to Position No. 1. The pressure obtained by the reduction shall be the non-load-weight full-service brake cylinder pressure but not to exceed 50 psi. If the brake cylinder pressure on the test gauge is in excess of 50 psi, then the pressure shall be reduced to 50 psi through the bleed cock.

**NOTE:** If the brake cylinder gauge pressure does not exceed 50 psi, then test leakage at the pressure obtained.

**10.2.5 TEST:** Observe the test gauge for leakage from the combined volumes of the brake cylinders and their related piping. The drop in pressure shall not exceed 3 psi in 1 minute.

## **11. Emergency Brake (Conductor's) Valve Test**

**NOTE:** The following test shall be performed for the first Emergency Brake Valve tested on the car. The remaining Emergency Brake Valves shall be tested in accordance with Section 11.2. For Emergency Brake Valves equipped with multiple operating mechanisms, each operating mechanism must be verified.

**11.1 TEST:** With the equipment fully charged and the Device handle in Position No. 1, open the emergency brake (conductor's) valve, observing carefully to ensure that there are no obstructions to the free and full movement of the operating mechanism and that there is no binding of parts. The opening of the emergency brake (conductor's) valve shall produce an emergency reduction.

**11.2** Repeat item 11.1.1 for each remaining emergency brake (conductor's) valve. Allow sufficient time after testing of each valve so that the system may reset and begin to charge. A full charge of the brake system is not required to test the function of the remaining Emergency Brake (Conductor's) Valves and application valves.

## **12. Variable Load Control**

For cars not equipped with a variable load control system, proceed to Section 13.

**NOTE:** This section provides a guide to testing the variable load control system. The test may be performed as described below, or the test may be modified or performed in any sequence to meet the specific operation of a particular variable load control system. The modified procedure shall agree with the original equipment manufacturer's requirements.

Cars equipped with EAB systems with electronic load correction shall be tested per Section 12 if applicable or in accordance with equipment manufacturer/operating authority's instructions.

### **12.1 Empty (Light) Car**

**12.1.1** Increase the Air Spring pressure to within  $\pm 1$  psi of the Empty (Light) Car pressure, as specified in Section 4.2.8.

**12.1.2** With the equipment fully charged, move the Device handle to Position No. 5 until a 27 psi brake pipe reduction is obtained; then slowly move the Device handle to Position No. 3 (Lap). When testing cars equipped with an accelerated, continuous service application feature (B-1 Quick Service Valve or Accelerated Application Valve), a greater quick service activity will be indicated by the continual decrease in brake pipe pressure. If brake pipe pressure has not stopped dropping before it reaches 55 psi, as indicated by the Device gauge, then move the Device handle to Position No. 2 until the brake pipe pressure stops reducing. Then immediately move the Device handle back to Position No. 3 (Lap).

**APTA PR-M-S-005-98, Rev. 4**  
**Code of Tests for Passenger Car Equipment Using Single Car Testing**

**12.1.3 TEST:** Allow 20 seconds for the system to stabilize. Ensure that the brake cylinder gauge pressure is within  $\pm 3$  psi of the Empty (Light) Car full-service brake cylinder pressure, as specified is correct.

**12.1.4** Move the Device handle to Position No. 1 and fully recharge the system.

**12.1.5** Move the Device handle to Position No. 3 (Lap).

**12.1.6** Open the Device  $\frac{3}{8}$  in. cock. The test shall produce an emergency brake application.

**12.1.7 TEST:** Allow 20 seconds for the system to stabilize. Ensure that the brake cylinder gauge pressure is within  $\pm 3$  psi of the Empty (Light) Car emergency brake cylinder pressure, as specified is correct.

**12.1.8** Close the Device  $\frac{3}{8}$  in. cock and move the Device handle to Position No. 1.

## **12.2 Loaded (Heavy) Car**

**12.2.1** Increase the Air Spring pressure to within  $\pm 1$  psi of the Loaded (Heavy) Car pressure, as specified in Section 4.2.8.

**12.2.2** With the equipment fully charged, move the Device handle to Position No. 5 until a 30 psi brake pipe reduction is obtained, and then slowly move the Device handle to Position No. 3 (Lap). When testing cars equipped with an accelerated, continuous service application feature (B-1 Quick Service Valve or Accelerated Application Valve), a greater quick service activity will be indicated by the continual decrease in brake pipe pressure. If brake pipe pressure has not stopped dropping before it reaches 55 psi, as indicated by the Device gauge, then move the Device handle to Position No. 2 until the brake pipe pressure stops reducing. Then immediately move the Device handle back to Position No. 3 (Lap).

**12.2.3 TEST:** Allow 20 seconds for the system to stabilize. Ensure that the brake cylinder gauge pressure is within  $\pm 3$  psi of the Loaded (Heavy) car full-service brake cylinder pressure, as specified is correct.

**12.2.4** Move the Device handle to Position No. 1 and fully recharge the system.

**12.2.5** Move the Device handle to Position No. 3 (Lap).

**12.2.6** Open the Device  $\frac{3}{8}$  in. cock. The test shall produce an emergency brake application.

**12.2.7 TEST:** Allow 20 seconds for the system to stabilize. Ensure that the brake cylinder gauge pressure is within  $\pm 3$  psi of the Loaded (Heavy) car emergency brake cylinder pressure, as specified is correct.

**12.2.8** Close the Device  $\frac{3}{8}$  in. cock.

## **13. Miscellaneous Devices**

If the car is equipped with any of the equipment listed below, it shall also be tested as part of the Single Car Test. At completion of previous testing, brake equipment will have brakes applied. Manufacturer/operating authority instructions shall be followed to condition equipment for the following tests.

### **13.1 Hand Brake/Parking Brake**

**13.1.1 TEST:** Hand brake/parking brake unit shall be tested in accordance with manufacturer/operating authority instructions.

## 13.2 Wheel Slide Protection Equipment

**13.2.1 TEST:** Wheel Slide equipment shall be tested in accordance with manufacturer/operating authority instructions.

## 13.3 Conductor's Signal System

**13.3.1 TEST:** Conductors signal systems shall be tested in accordance with manufacturer's instructions. If car is equipped with air signal equipment, it shall be tested in accordance with Instruction Leaflet No. 2377-2, July 1942.

## 13.4 Electropneumatic Operation

**13.4.1 TEST:** Cars with Electropneumatic operation capabilities shall be tested in accordance with manufacturer/operating authority instructions.

## 13.5 Ancillary Pneumatic Equipment

**13.5.1 TEST:** Any ancillary pneumatic equipment not described by this standard shall be tested in accordance with manufacturer/operating authority instructions. Brake system shall not be adversely affected by ancillary pneumatic equipment operation.

**13.5.2 TEST:** If ancillary pneumatic equipment is cut out during leakage tests as described in Section 7, then appropriate leakage tests shall be performed on ancillary pneumatic equipment. The summation of all leakages shall not exceed the limits specified in Section 7.

## 14. Completion of Testing

### 14.1 Test Equipment

**14.1.1** Safely remove all gauges from their respective test points where applicable.

**14.1.2** If the gauges were connected by the removal of pipe plugs, leakage shall be tested. No pipe plug leakage is allowed.

**14.1.3** Safely disconnect the Device from the car. Connect a dummy coupling to all hose connections and the Device to prevent contamination from dust or dirt.

### 14.2 Final Car Preparation

**14.2.1** Ensure that hand brake/parking brake is applied.

**14.2.2** Ensure that all car equipment is restored to operating configuration, as specified by operating authority.

**14.2.3** Record car and test information as specified by the operating authority and federal regulation.

## 15. Single Car Test Device—Testing

### 15.1 Daily Test for Single Car Testing Device

**15.1.1** This test is to be performed at least once each day of use. Connect the Device to a source of clean, dry air, which shall be maintained at **120 psi** (100 psi) minimum to the Device during test for proper operation and results. An efficient air filter in the supply line ahead of the regulating (feed) valve shall be installed. Before the Device is connected to the supply line, the supply line shall be blown out. Open the FLOWRATOR by-pass cock and close the  $\frac{3}{8}$  in. test cock.

**APTA PR-M-S-005-98, Rev. 4**  
**Code of Tests for Passenger Car Equipment Using Single Car Testing**

**15.1.2** Move the Device handle to Position No. 2 and note a continuous flow of air at the Device brake pipe hose coupling.

**15.1.3** Move the Device handle to Position No. 3 (Lap). Test for leakage at brake pipe connection and rotary valve exhaust. This leakage, when detected with soap suds, shall not exceed a 1 in. bubble in 5 seconds.

**15.1.4** Move the Device handle to Position No. 2. Close and open FLOWRATOR by-pass cock. Observe that the ball does not stay at the top of the tube.

**15.1.5** Move the Device handle to Position No. 3 (Lap). Couple the test coupling with orifice to the brake pipe coupling end (BP) of the Device. Move the Device handle to Position No 1. Close the FLOWRATOR by-pass cock. Note that the FLOWRATOR ball rises and floats in the tube in the zone between the Red condemning line and the top of the tube (Test applies for both 90 psi and 110 psi operation). The test coupling may be connected to the end of a hose connected to the Device as described in Section 4.1.2.2. However, a greater time shall be given before condemning the FLOWRATOR due to the increased volume of the hose.

- a) If the Device fails, check coupling and gaskets for leakage (none allowed). Inspect the exhaust end of test coupling to ensure that it is clean and free of obstructions. If this does not correct the failure, then the FLOWRATOR shall not be used to qualify leakage or fully charged system until the Device and test coupling are returned for maintenance to requalify the test coupling and FLOWRATOR.
- b) If the Device FLOWRATOR has failed the above test, it may be used by following the procedures for determination of leakage/fully charged system outlined in Section 4.1.7.

**15.1.6** Move the Device handle to Position No. 3 (Lap). Open the FLOWRATOR by-pass cock and the Device  $\frac{3}{8}$  in. cock.

**15.1.7** Remove and properly store the test coupling. Close the Device  $\frac{3}{8}$  in. cock.

## **15.2 92-day Test for the Single Car Testing Device and Test Coupling**

The Device shall be tested at either 110 psi or 90 psi based on the operating pressure of the brake equipment being tested and pass the procedure using either the standard test rack or the alternate test rack according to **Table 3**. If the Device is used for 110 psi and 90 psi type equipment then the 110 psi sections shall be used.

**TABLE 3**  
Test Procedures

<b>Test Rack</b>	<b>Test Device</b>	<b>Test Coupling</b>
Standard Test Rack	15.2.1	15.2.3
Alternate Test Rack	15.2.2	15.2.4

The Single Car Testing Device shall be maintained according to the requirements of Section 3.

The test coupling is part of the Device and shall be returned for requalification with the Device. Testing of the test coupling is to be performed according to Section 15.2.3 when using the standard test rack and Section 15.2.4 when using the alternate standard test rack.

As often as service conditions require, the rotary valve shall be lubricated with a suitable grease or lubricating oil (AAR Spec M-912). Lubricate the standard quick opening diaphragm cock cam with a small amount of grease (AAR Spec M-914).

**APTA PR-M-S-005-98, Rev. 4**  
**Code of Tests for Passenger Car Equipment Using Single Car Testing**

The Device test gauge shall be compared with a master gauge for accuracy as often as the Device itself is being tested. The master gauge is to be calibrated according to ASME standards. The calibration of the master gauge shall be performed annually or as required by ASME standards.

The strainer filter shall be replaced annually unless service conditions warrant a more frequent replacement.

**15.2.1 Test Procedure for Single Car Testing Device with FLOWRATOR on Standard Test Rack**

**FIGURE 6**  
 Standard Rack for Testing Passenger Single Car Testing Device

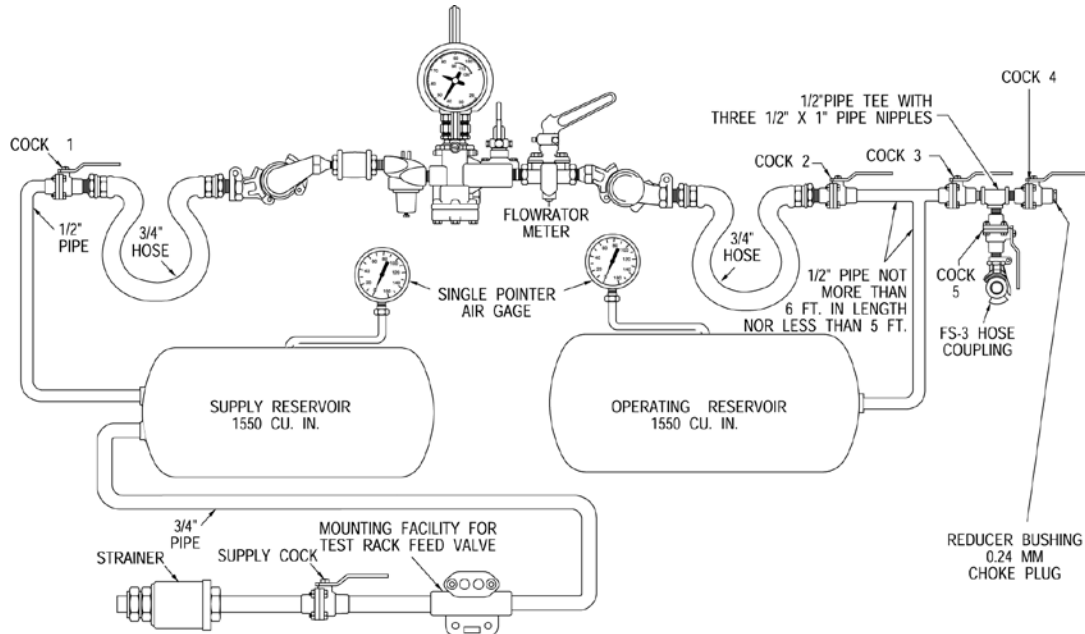

Qty.	Description	Wabtec PC	Knorr PC
1	Air strainer	70800	700270*
1	3/4 in. supply cock OR OR diaphragm cock	572465 572460 519873	784407-0121, 704498* —
1	Type DB-24-B feed valve pipe bracket	542011	733115*
5	1/2 in. cutout cocks (Nos. 1, 2, 3, 4, 5) OR diaphragm cock	572464 572459 96878	784405-0121, 704495* —
1	Supply reservoir	530851	704672*
1	Operating reservoir	530869	702996*
2	Single pointer air gauge	88882	710216, 700437*
1	Choke fitting with choke(s)	655009	809906*
2	3/4 in. x 56 in. hose with 2 1/2 in. threaded nipples	549772	—
2	3/4 in. x 2 1/2 in. face bushing	537659	—
3	FS-3 hose coupling	87817	782884, 700510*

\* Part number is obsolete but may be used if available.



**APTA PR-M-S-005-98, Rev. 4**  
**Code of Tests for Passenger Car Equipment Using Single Car Testing**

**15.2.1.1** Attach the Device to the rack as illustrated by **Figure 6**. Open the supply cock, cock 1, cock 2 and FLOWRATOR by-pass cock. Move the Device handle into Position No. 1. Adjust the test rack regulating valve to close between **120–125 psi** (100 psi) as indicated on the test rack supply reservoir gauge.

**NOTE:** If the pressure indicated on the test rack supply reservoir gauge should rise above **125 psi** (100 psi), then the Device  $\frac{3}{8}$  in. cock should be opened to release air trapped in the system. While the Device  $\frac{3}{8}$  in. cock is open, the reducing or feed valve should be turned down below the set pressure. Once the test rack feed valve or the Device reducing valve set point has been turned back down, close the Device  $\frac{3}{8}$  in. cock, and readjust the feed or reducing valve. The pressure setting of either the Device reducing valve or the test rack feed valve shall be set by increasing to the set pressure and never by decreasing to the set pressure.

**15.2.1.2** Verify the Device reducing valve is set to close at **110 psi** (90 psi) as indicated by the operating reservoir gauge. If the Device reducing valve does not close at **110 psi** (90 psi), then adjust the valve to properly close at **110 psi** (90 psi).

**NOTE:** If the pressure indicated on the test rack operating reservoir gauge should rise above **110 psi** (90 psi), then the Device  $\frac{3}{8}$  in. cock should be opened to release air trapped in the system. While the Device  $\frac{3}{8}$  in. cock is open, the reducing valve should be turned down below the set pressure. Once the reducing valve set point has been turned back down, close the Device  $\frac{3}{8}$  in. cock, and readjust the reducing valve. The pressure setting of the Device reducing valve shall be set by increasing to the set pressure and never by decreasing to the set pressure.

**15.2.1.3** Operate the Device several times by moving the Device handle from Position No. 1 to Position No. 6, finally leaving the handle in Position No. 3 (Lap).

**15.2.1.4** Close Cock 1, and open the Device  $\frac{3}{8}$  in. cock until the operating reservoir gauge indicates zero (0) psi. Close the Device  $\frac{3}{8}$  in. cock.

**15.2.1.5** Commence test with all numbered cocks closed and the Device handle in Position No. 3 (Lap). Open Cock 1 and the Device  $\frac{3}{8}$  in. cock. Coat the opening of the  $\frac{3}{8}$  in. cock with soap suds in order to detect rotary valve leakage to brake pipe. Leakage must not exceed a 1 in. bubble in 5 seconds.

**15.2.1.6** Close the  $\frac{3}{8}$  in. cock and move the Device handle to Position No. 6, and then coat the Device exhaust port with soap suds in Positions No. 6, 5, 4, 3, 2 and 1 consecutively. Leakage must not exceed a 1 in. bubble in 5 seconds.

**15.2.1.7** Open cock 2, and when operating reservoir pressure reaches 38 psi, move the Device handle to Position No. 2. Note that the operating reservoir charges from 40 to 45 psi in **21 to 26 seconds** (28 to 33 seconds).

**15.2.1.8** Close FLOWRATOR by-pass cock and move the Device handle to Position No. 1. Note that operating reservoir charges from 50 to 80 psi in **10 to 16 seconds** (20 to 25 seconds).

**15.2.1.9** Open the FLOWRATOR by-pass cock. After the operating reservoir is charged to **110 psi** (90 psi), compare OPERATING RESERVOIR and DEVICE gauges and ensure that the gauge hands register within  $\frac{1}{2}$  psi.

**15.2.1.10 FLOWRATOR Ball Test**

- a) Close the FLOWRATOR by-pass cock. There should be no indication of airflow. Open the FLOWRATOR by-pass cock and open Cocks 3 and 4, allowing air to vent through the choke fitting (or chokes) of the test rack.

**APTA PR-M-S-005-98, Rev. 4**  
**Code of Tests for Passenger Car Equipment Using Single Car Testing**

- b) Close the FLOWRATOR by-pass cock. The ball should rise and float in the tube in the zone between the condemning line and the top of the tube.

**NOTE:** If the FLOWRATOR fails to pass this test, the ball and glass tube of the FLOWRATOR should be cleaned using a non-residue-producing solution to remove any oil or foreign matter, which may be carried into the Device. When the tube is properly installed in the FLOWRATOR cock, the dot on the tube should be below the condemning line.

**15.2.1.11** Close Cock 3 and wait until flow of air from choke fitting stops; then open the FLOWRATOR by-pass cock and close Cock 4.

**Wait a minimum of 45 seconds before commencing each of the following tests:**

- a) Move the Device handle to Position No. 4. The operating reservoir pressure shall reduce from **100 to 90 psi** (80 to 70 psi) in **8.5 to 11.5 seconds** (11.5 to 14.5 seconds). At the completion of the test, move the Device handle to Position No. 1 and recharge to **110 psi** (90 psi).
- b) Move the Device handle to Position No. 5. The operating reservoir pressure shall reduce from **100 to 60 psi** (80 to 40 psi) in **10 to 13 seconds** (14.5 to 17.5 seconds). At the completion of the test, move the Device handle to Position No. 1 and recharge to **110 psi** (90 psi).
- c) Move the Device handle to Position No. 6. The operating reservoir pressure shall reduce from **100 to 40 psi** (80 to 30 psi) in **5 to 9 seconds** (6 to 9.5 seconds). At the completion of the test, move the Device handle to Position No. 1 and recharge to **110 psi** (90 psi).
- d) Move the Device handle to Position No. 3 (Lap). Open the Device  $\frac{3}{8}$  in. cock and observe on the operating reservoir gauge that the operating reservoir pressure reduces from **110 to 20 psi** (90 to 20 psi) in **3.75 to 4.25 seconds** (3 to 3.5 seconds).
- e) At the completion of the test, close Cock 1, open the Device  $\frac{3}{8}$  in. cock and allow the Device Gauge to decrease to zero (0) psi. Close the Device  $\frac{3}{8}$  in. cock, and close the remaining test rack cocks. Remove the Device from the test rack.

**15.2.2 Test Procedure for Standard Single Car Testing Device with FLOWRATOR on**

**Alternate Test Rack**

**FIGURE 7**  
 Alternate Rack for Testing the Passenger Single Car Testing Device

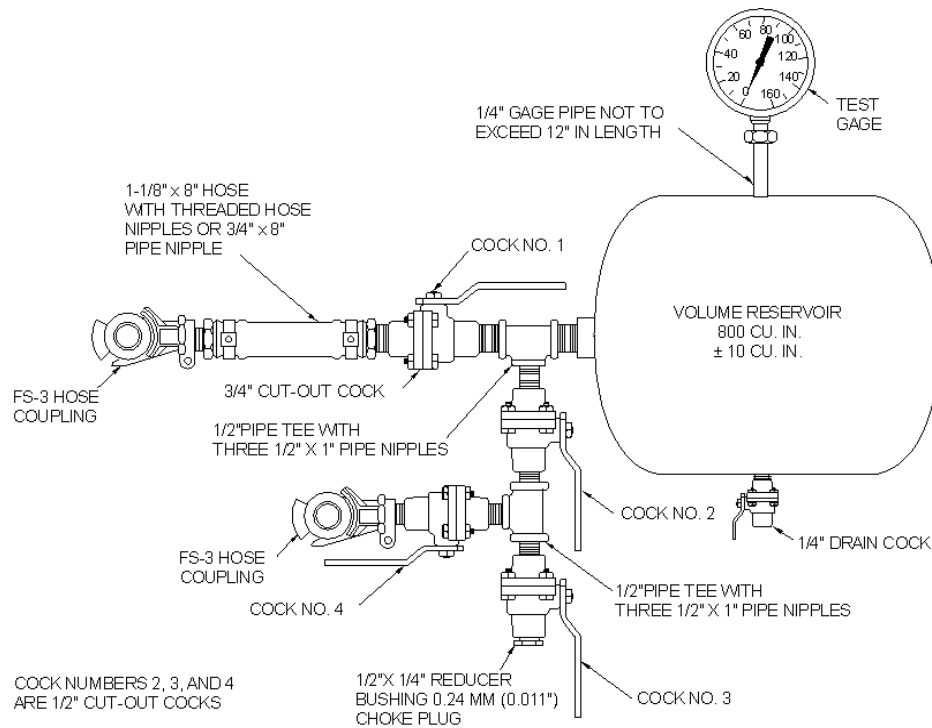

Qty.	Description	Wabtec PC	Knorr PC
1	FS-3 hose coupling	87737	782884, 700510*
1	1 1/8 in. x 8 in. hose with threaded nipples	516188	779071-0110
	Or 3/4 in. x 8 in. pipe nipple	—	—
1	3/4 in. supply cock	572465 572460	784407-0121, 704498*
	OR diaphragm cock	519873	—
3	1/2 in. cutout cocks (Nos. 2, 3, 4)	572464, 572459	784405-0121, 704495*
	OR diaphragm cock	96878	—
1	Volume reservoir	530848	704324
1	1/4 in. gauge pipe not to exceed 2 in. length	—	—
1	Single pointer air gauge	88882	710216, 700437*
1	Choke fitting with choke(s)	655009	809906*
1	1/4 in. drain cock	580867, 41814*	760691

\* Part number is obsolete but may be used if available

For air supply adjustment, see Sections 15.2.2.1–15.2.2.4. Skip to Section 15.2.2.5 if the supply line is already regulated.

**APTA PR-M-S-005-98, Rev. 4**  
**Code of Tests for Passenger Car Equipment Using Single Car Testing**

**15.2.2.1** With all of the cocks closed, attach supply line to test rack volume reservoir coupling (**Figure 7**). The air supply shall meet the requirements as specified in Section 4.1.2.1.

**15.2.2.2** Open the supply cock, FLOWRATOR by-pass cock and Cock 1. Adjust the supply regulating valve to close between **120 and 125 psi** (at 100 psi), as indicated by the test gauge. (*It is recommended that this regulating valve setting be at 120 psi.*)

**NOTE:** If the pressure indicated on the test rack volume reservoir gauge should rise above **125 psi** (100 psi), then the volume reservoir drain cock should be opened to release air trapped in the system. While the drain cock is open, the reducing valve should be turned down below the set pressure. Once the reducing valve set point has been turned back down, close the drain cock and readjust the reducing valve. The pressure setting of the reducing valve shall be set by increasing to the set pressure and never by decreasing to the set pressure.

**15.2.2.3** Close the supply cock and slowly open the reservoir drain cock and reduce test rack volume reservoir pressure to zero (0) psi.

**15.2.2.4** Disconnect the supply line from the volume reservoir coupling and close the reservoir drain cock.

**15.2.2.5** Attach the FLOWRATOR end of the Device to the volume reservoir coupling of the test rack (**Figure 7**), and then couple the supply line to the Device end with regulating valve.

**15.2.2.6** Open the supply cock and Cock 1. Cycle the valve several times by moving the Device handle from Position No. 1 to Position No. 6, finally leaving the handle in Position No. 1.

**15.2.2.7** Verify that the Device reducing valve is set to close at **110 psi** (90 psi) as indicated by the test rack volume reservoir gauge. If the Device reducing valve does not close at **110 psi** (90 psi), then adjust the reducing valve to properly close at **110 psi** (90 psi).

**NOTE:** If the pressure indicated on the test rack volume reservoir gauge should rise above **110 psi** (90 psi), then the Device  $\frac{3}{8}$  in. cock should be opened to release air trapped in the system. While the Device  $\frac{3}{8}$  in. cock is open, the reducing valve should be turned down below the set pressure. Once the reducing valve set point has been turned back down, close the Device  $\frac{3}{8}$  in. cock, and readjust the reducing valve. The pressure setting of the Device reducing valve shall be set by increasing to the set pressure and never by decreasing to the set pressure.

**15.2.2.8** Move the Device handle to Position No. 6 and allow the test rack volume reservoir gauge to decrease to 0 psi, and then move the Device handle to Position No. 3 (Lap). Close Cock 1 and open the Device  $\frac{3}{8}$  in. cock. Coat the opening of the  $\frac{3}{8}$  in. cock with soap suds to detect rotary valve leakage to the brake pipe. Leakage must not exceed a 1 in. bubble in 5 seconds.

**15.2.2.9** Close the  $\frac{3}{8}$  in. cock and move the Device handle to Position No. 6. Then coat the Device exhaust port with soap suds in Positions No. 6, 5, 4, 3, 2 and 1 consecutively. Leakage must not exceed a 1 in. bubble in 5 seconds.

**15.2.2.10** With the Device handle in Position No. 1, open Cock 1. After the volume reservoir is charged to **110 psi** (90 psi), compare VOLUME RESERVOIR and DEVICE gauges and note that gauge hands register within  $\frac{1}{2}$  psi. Adjust DEVICE gauges if necessary.

**15.2.2.11 FLOWRATOR Ball Test**

- a) Close the FLOWRATOR by-pass cock. There should be no indication of air flow. Open the FLOWRATOR by-pass cock and open Cocks 2 and 3, allowing air to vent through the choke fitting (or chokes) of the test rack.
- b) Then close the FLOWRATOR by-pass cock. The ball should rise and float in the tube in the zone between the **110 psi** (90 psi) condemning line and the top of the tube.

**NOTE:** If the FLOWRATOR fails to pass this test, the ball and glass tube of the FLOWRATOR should be cleaned, using a non-residue-producing solution to remove any oil or foreign matter that may be carried into the Device. When the tube is properly installed in the FLOWRATOR cock, the dot on the tube should be below the condemning line.

**15.2.2.12** Close cocks 2 and 3, and open the FLOWRATOR by-pass cock.

**Wait a minimum of 45 seconds before commencing each of the following tests:**

**15.2.2.13** Move the Device handle to Position No. 4 and reduce the volume reservoir pressure to approximately 30 psi. Move the Device handle to Position No. 2. Note that the operating reservoir charges from 40 to 50 psi in **21.5 to 28.5 seconds** (27 to 33 seconds). At the completion of the test, move the Device handle to Position No. 1 and charge the reservoir to **110 psi** (90 psi).

- a) Move the Device handle to Position No. 4. The volume reservoir pressure shall reduce from **100 to 50 psi** (80 to 50 psi) in **35 to 41 seconds** (24 to 26 seconds). At the completion of the test, move the Device handle to Position No. 1 and recharge to **110 psi** (90 psi).
- b) Move the Device handle to Position No. 5. The volume reservoir pressure shall reduce from **100 to 40 psi** (80 to 40 psi) in **10 to 13 seconds** (7.5 to 9.5 seconds). At the completion of the test, move the Device handle to Position No. 1 and recharge to **110 psi** (90 psi).
- c) Move the Device handle to Position No. 6. The volume reservoir pressure shall reduce from **110 to 40 psi** (80 to 20 psi) in **3 to 6 seconds** (4 to 7 seconds). At the completion of the test, move the Device handle to Position No. 1 and recharge to **110 psi** (90 psi).
- d) Move the Device handle to Position No. 3 (Lap). Open the Device  $\frac{3}{8}$  in. cock and observe the test rack volume reservoir gauge to ensure that the volume reservoir pressure reduces from **110 to 20 psi** (90 to 20 psi) in **1.5 to 2.25 seconds** (1.5 to 2 seconds).
- e) At the completion of the test, close the supply cock. Open the Device  $\frac{3}{8}$  in. cock, allow the gauge to decrease to zero (0) psi and close the Device  $\frac{3}{8}$  in. cock. Remove the Device from the test rack.

**NOTE:** If the measured times are long, then check for the proper choke size.

**15.2.3 Test Procedure for Device Test Coupling on Standard Test Rack (Figure 6)**

**15.2.3.1** Move the Device handle to Position No. 1, open Cocks 1 and 2, and open the FLOWRATOR by-pass cock.

**15.2.3.2** Close Cocks 4 and 5.

**15.2.3.3** Open Cock 3.

**15.2.3.4** Attach the test coupling to the FS-3 hose coupling located after Cock 5.

**15.2.3.5** Charge the volume reservoir to 110 psi and wait 1 minute.

**APTA PR-M-S-005-98, Rev. 4**  
**Code of Tests for Passenger Car Equipment Using Single Car Testing**

**15.2.3.6** Move the Device handle to Position No. 3 and, with the FLOWRATOR by-pass open, open Cock 5 and observe that the volume reservoir gauge reduces from 106 to 101 psi within 2 minutes, 10 seconds, to 2 minutes, 29 seconds.

**15.2.3.7** Close Cock 3 and wait until the flow of air from the 0.24 mm choke fitting stops.

**15.2.3.8** Close Cock 5 and remove the test coupling.

**15.2.3.9** If the choke fitting fails this test, then carefully replace the filter and blow the choke clean. Do not use metal tools to clean the choke. An appropriate cleaning solution may be used as needed. Once the choke is cleaned or replaced, repeat Section 15.2.3.

**15.2.4 Test Procedure for Device Test Coupling on Alternate Test Rack (Figure 7)**

**15.2.4.1** Move the Device handle to Position No. 1, open Cock 1 and open the FLOWRATOR by-pass cock.

**15.2.4.2** Close Cocks 3 and 4.

**15.2.4.3** Open Cock 2.

**15.2.4.4** Attach the FLOWRATOR end of the Device to the volume reservoir coupling of the test rack (**Figure 7**) then couple the supply line to the Device end with regulating valve. The air supply shall meet the requirements specified in Section 4.1.2.1.

**15.2.4.5** Attach the test coupling to the FS-3 hose coupling located after Cock 4.

**15.2.4.6** Charge the volume reservoir to 110 psi and wait 1 minutes.

**15.2.4.7** Move the Device handle to Position No. 3 and, with the FLOWRATOR by-pass open, open Cock 4 and observe that the volume reservoir gauge reduces from 106 to 101 psi within 1 minutes, 9 seconds, to 1 minutes, 20 seconds.

**15.2.4.8** Close Cock 2 and wait until flow of air from the 0.24 mm choke fitting stops.

**15.2.4.9** Close Cock 4 and remove the test coupling.

**15.2.4.10** If the choke fitting fails this test, then carefully replace the filter and blow the choke clean. Do not use metal tools to clean the choke. An appropriate cleaning solution may be used as needed. Once the choke is cleaned or replaced, repeat Section 15.2.4.

## References

ASME B40.100 – “Pressure Gauges and Gauge Attachments”, 2013

AAR Spec M-912 – “Oil, Control Valves”, Adopted: 1941; Last Revised: 2002

AAR Spec M-914 – “Brake Cylinder Lubricant”, Adopted: 1942; Last Revised: 2003

## Definitions

**Back-up mode:** The EAB system being powered and active with microprocessors controlling and monitoring the functionality of the system.

**Normal mode:** The EAB system in an un-powered state with only pneumatic functionalities.

## Abbreviations and acronyms

<b>AAR</b>	Association of American Railroads
<b>ASME</b>	American Society of Mechanical Engineers
<b>BP</b>	brake pipe
<b>EAB</b>	Electronic Air Brake
<b>FRA</b>	Federal Railroad Administration
<b>min</b>	minutes
<b>MR</b>	main reservoir
<b>NATSA</b>	North American Transportation Services Association
<b>OR</b>	Operating Reservoir
<b>PC</b>	Part Code
<b>psi</b>	pounds per square inch (short for psig unless otherwise specified)
<b>psig</b>	pounds per square inch gauge
<b>s</b>	seconds

## Summary of document changes

- Document formatted to the new APTA standard format.
- Sections have been moved and renumbered.
- Scope and summary moved to the front page.
- Definitions, abbreviations and acronyms moved to the rear of the document.
- Two new sections added: “Summary of document changes” and “Document history.”
- Some global changes to section headings and numberings resulted when sections dealing with references and acronyms were moved to the end of the document, along with other cosmetic changes, such as capitalization, punctuation, spelling, grammar and general flow of text.
- General – Change all gage to gauge. Webster Dictionary definition of gage does not agree with how it is used in this document.
- General - Removed the reference the troubleshooting.
- General – Added "TEST" step to where record should be made. Similar to AAR S-486. Bolded the statement.
- General – Added TEST in bold at the beginning of each step that required PASS/FAIL criteria.
- Keywords – Added 26-C and Brake Test.
- Scope – Updated dates to reflect latest revision.
- Scope – Broadened to include brake type equipment equivalent to 26-C.
- Scope – Added statement “must have M-005 in hand when requested by FRA.”

**APTA PR-M-S-005-98, Rev. 4**  
**Code of Tests for Passenger Car Equipment Using Single Car Testing**

- 1 – Electronic Air Brake Systems added as application.
- 2 – Removed date as all Devices should now be equipped as such.
- 2.1 – Added sentence about test coupling.
- 3.1 & 3.2 – Extended shelf life out to 1 year. Reworded the statement to agree with S-486 Section 2.2.
- 4.1.7 – Changed may to shall.
- 4.2.3 - The term “Cut Out” (CLOSED) was amended to also designate a cut-out cock that will stop the flow of air between equipment components.
- 4.2.4 & 4.2.5 – Added "Tests of car equipment shown herein may be performed in a different order than listed in this procedure provided that the conditions for the test, and the performance criteria described, are adhered to."
- 4.2.4 – Wording added to say "... not identified or provided a test procedure within this..."
- 4.2.5 – Rewording of Section 4.2.5.
- 4.2.7 & 4.2.8 – Added Sections, renumbered original Section 4.2.7 to Section 4.2.9.
- 5.1.1 – Car motion changed to car movement.
- 5.2.3 – Added "Locomotive functions (service control of brake pipe) of cab cars shall be tested per current FRA regulations."
- 5.2.5 – Added "...equipment connected to the main reservoir shall..."
- 6.1.1 – Broken down into in to separate steps.
- 6.1.7 – Added new Section 6.1.7 and note.
- 6.1.8 – Added test step for verifying the 1" main reservoir check valve.
- 6.1.9 – Added new Section 6.1.9.
- 7.2 – Added all of Section 14.3 to Section 7.2 as a part of Main Reservoir Leakage.
- 7.2.2.6 – Added new Section 7.2.2.6.
- 8.1.1 – Changed pneumatically controlled to pneumatic cutoff valve.
- 8.2.1 – Changed BP reduction from 25 psi to 27 psi as 27 pound reduction ensures that a Full Service brake application is achieved for each test.
- 8.2.2 – Combined Section 8.2.2 “Allow 20 seconds settling time for brake cylinder pressure then note that brake cylinder pressure increases no more than 3 psi in 1 minute.” with Section 8.2.1 and deleted the rest.
- 8.2.3 – Moved 20 second stabilization period to the beginning of the Section 8.2.3.
- 8.3 – Section 13 moved to Section 8.3.
- 8.3 – Added EAB statement.
- 8.3.1 – Change section title to Direct Release Test.
- 8.3.1.1 – Changed BP reduction from 25 to 27 as 27 pound reduction ensures that a Full Service brake application is achieved for each test.
- 8.5 – Combined Section 8.5 with Section 8.4 since the steps should be done sequentially.
- 8.5.2 – Use of general terms instead of control valve to cover electropneumatic systems
- 8.5.2 – Added "or by a reduction in brake cylinder as measured on the brake cylinder gauge."
- 8.5.4 – Removed all of Section 8.5.4 and renumbered Section 8.5.5 to 8.5.4.
- 9.1.2 – Changed BP reduction from 30 to 27 psi as 27 pound reduction ensures that a Full Service brake application is achieved for each test.
- 9.1.6 – Added Auxiliary after “last venting” in the first sentence and language for safely removing plugs.
- 9.2.1 – Added new Section 9.2.1.
- 9.2.3 – Changed BP reduction from 30 to 27 psi as 27 pound reduction ensures that a Full Service brake application is achieved for each test.
- 9.3 – Added sentence to say the brakes shall be in an emergency application before the start of this test.



**APTA PR-M-S-005-98, Rev. 4**  
**Code of Tests for Passenger Car Equipment Using Single Car Testing**

- 9.3.1.1 – Combined with Section 9.3.1.
- 10 – Removed the wording of Port 10 and added 26-C 10 port and 16 exhaust.
- 10.1 – Added control valve leakage.
- 10.1 – Added EAB statement.
- 10.1.3 – Changed BP reduction from 26 to 27 as 27 pound reduction ensures that a Full Service brake application is achieved for each test.
- 10.1.3 & 10.2.4 – Added note to say that if it doesn't reach 50 psi then that is okay.
- 10.2 – Rearranged steps and added new step.
- 10.2.4 – Changed BP reduction from 26 to 27 as 27 pound reduction ensures that a Full Service brake application is achieved for each test.
- 10.2.6 – Added "or brake cylinder gauge."
- 11.2 - Turned it into Section 11.1.2.
- 12 – Added EAB statement.
- 12.1.2 – Changed BP reduction from 30 to 27 psi as 27 pound reduction ensures that a Full Service brake application is achieved for each test.
- 12.2.2 – Changed BP reduction from 30 to 27 psi as 27 pound reduction ensures that a Full Service brake application is achieved for each test.
- 13.1.2 – Changed from 25 to 27 psi as 27 pound reduction ensures that a Full Service brake application is achieved for each test.
- 14.6 – Added “Ancillary equipment should be Cut In for leakage test purposes.”
- 14.6.2 – Added leakage test for ancillary equipment.
- 15 - Rewritten to combine **110** and (90) PSI versions.
- 16.1.1.1 – Added "This test is to be performed at least once each day of use." at the beginning of Section 16.1.1.1. Added "Close the 3/8" test cock." to the end of Section 16.1.1.1.
- Figure 6 and 7 – Updated the tables.
- Table 4 – Added K Triple, AB control, ABD control to the table and their respective documents to the table and APTA will have the documents available. Added this to the back of the publication as an appendix.

**Document history**

<b>Document Version</b>	<b>Working Group Vote</b>	<b>Public Comment/ Technical Oversight</b>	<b>CEO Approval</b>	<b>Policy &amp; Planning Approval</b>	<b>Publish Date</b>
First published					June 15, 1998
First revision					May 5, 2003
Second revision					May 18, 2007
Third revision					June 30 2012
Fourth revision	August 31, 2017	September 30, 2017	October 14, 2017	July 25, 2018	July 27, 2018

## Annex A – Equipment-Dependent Instructions

Please refer **Table 4** to determine which dated publication of Association of American Railroads Instruction Pamphlet No. 5039-4 Single Car Testing Device - Code of Tests is appropriate for the equipment being tested. Copies of these publications may be obtained from the APTA website.

**TABLE 4**  
 Equipment-Dependent Instructions

Equipment Type	Instruction Pamphlet No.	Date of Last Issue
D-22 Type Control Valve	5039-4, Sup 3	April 1, 1991
U-12-B Type Control Valve	5039-4, Sup 3	April 1, 1991
U-12 Type Control Valve	5039-4, Sup 1	November 1980
No. 3 Type Control Valve	5039-4, Sup 1	November 1980
L Type Triple Valve	5039-4, Sup 1	November 1980
P Type Triple Valve	5039-4, Sup 1	November 1980
*PS Type Triple Valve	5039-4, Sup 1	November 1980
K Triple Valve	5039-4, Sup 1	January 1956
AB Control Valve	5039-4, Sup 1	April 1, 1987
*PS does not refer to Electropneumatic overlay type equipment.		

- Equipment testing as described above may be done using Standard and Alternate Standard Testing Device as described in those publications
- Passenger cars equipped with AB Type Control Valves and newer freight-based brake systems shall be tested using equipment manufacturer/operating authority approved procedures in accordance with current Federal Regulations.
- For testing Conductor’s Air Signal Equipment, please refer to the following publication:  
 Conductor’s Air Signal Instruction Leaflet No. 2377-2, July 1942